

ARMY
NAVY
AIR FORCE

TM 11-6130-416-14
EE010-BJ-MMA-010/E154 DCDUAL
T.O. 35C1-2-847-1

TECHNICAL MANUAL

OPERATOR'S, ORGANIZATIONAL,
DIRECT SUPPORT AND GENERAL SUPPORT
MAINTENANCE MANUAL
FOR

POWER SUPPLY, DUAL DC
(H-P MODEL 6255A)
(NSN 6130-00-065-6811)

DEPARTMENTS OF THE ARMY, NAVY, AND AIR FORCE

31 JANUARY 1983



5

SAFETY STEPS TO FOLLOW IF SOMEONE IS THE VICTIM OF ELECTRICAL SHOCK

1

DO NOT TRY TO PULL OR GRAB THE INDIVIDUAL

2

IF POSSIBLE, TURN OFF THE ELECTRICAL POWER

3

IF YOU CANNOT TURN OFF THE ELECTRICAL POWER, PULL, PUSH, OR LIFT THE PERSON TO SAFETY USING A WOODEN POLE OR A ROPE OR SOME OTHER INSULATING MATERIAL

4

SEND FOR HELP AS SOON AS POSSIBLE

5

AFTER THE INJURED PERSON IS FREE OF CONTACT WITH THE SOURCE OF ELECTRICAL SHOCK, MOVE THE PERSON A SHORT DISTANCE AWAY AND IMMEDIATELY START ARTIFICIAL RESUSCITATION

INSERT LATEST CHANGED PAGES. DESTROY SUPERSEDED PAGES.

LIST OF EFFECTIVE PAGES

Dates of issue for original and changed pages are:

Original . . . 0 . . .

TOTAL NUMBER OF PAGES IN THIS PUBLICATION IS 83 CONSISTING OF THE FOLLOWING:

Page No.	# Change No.	Page No.	# Change No.	Page No.	# Change No.
Title	0				
A	0				
i - vii	0				
viii Blank	0				
1-1 - 1-4	0				
2-1 - 2-2	0				
3-1 - 3-8	0				
4-1 - 4-6	0				
5-1 - 5-23	0				
5-24 - Blank	0				
A-1	0				
A-2 Blank	0				
B-1 - B-4	0				
C-1 - C-2	0				
D-1	0				
D-2 Blank	0				
E-1	0				
E-2 Blank	0				
Index-1 - Index-10	0				
Report of Errors	0				
FO-1 - FO-2	0				

Zero in this column indicates an original page.

WARNING

DANGEROUS VOLTAGE

Is Used in the Operation of this Equipment

DEATH ON CONTACT

may result if personnel fail to observe safety precautions

Never work on electronic equipment unless there is another person nearby who is familiar with the operation and hazards of the equipment and who is competent in administering first aid. When the technician is aided by operators, he must warn them about dangerous areas.

Whenever possible, the power supply to the equipment must be shut off before beginning work on the equipment. Take particular care to ground every capacitor likely to hold a dangerous potential. When working inside the equipment, after the power has been turned off, always ground every part before touching it.

Be careful not to contact high-voltage connections when installing or operating this equipment.

Whenever the nature of the operation permits, keep one hand away from the equipment to reduce the hazard of current flowing through vital organs of the body.

Do not be misled by the term "low voltage." Potentials as low as 50 volts may cause death under adverse conditions.

WARNING

Do not touch heat sinks or power transistors mounted on heat sinks as they may be very hot after the instrument has been on and operating.

CAUTION

Do not directly short out any of the large capacitors as it places too much stress on them. Discharge capacitors through a load resistor.

This manual contains copyright material reproduced by permission of the Hewlett-Packard Company.

TM 11-6130-416-14
EE010-BJ-MMA-010/E154 DCDUAL
T.O.35C1-2-847-1

TECHNICAL MANUAL
NO. 11-6130-416-14
TECHNICAL MANUAL
EEO10-BJ-MMA-010/E154 DCDUAL
TECHNICAL ORDER
NO. 35CI-2-847-1

DEPARTMENTS OF THE ARMY,
THE NAVY,
AND THE AIR FORCE

Washington, DC, 31 January 1983

OPERATOR'S, ORGANIZATIONAL, DIRECT SUPPORT, AND GENERAL SUPPORT

MAINTENANCE MANUAL

FOR

POWER SUPPLY, DUAL DC

(H-P Model 6255A)

(NSN 6130-00-065-6811)

REPORTING ERRORS AND RECOMMENDING IMPROVEMENTS

You can help improve this manual. If you find any mistakes or if you know of a way to improve the procedures, please let us know. Mail your letter, DA Form 2028 (Recommended Changes to Publications and Blank Forms), or DA Form 2028-2 located in back of this manual direct to: Commander, US Army Communications-Electronics Command and Fort Monmouth, ATTN: DRSEL-ME-MP, Fort Monmouth, NJ 07703.

For Air Force, submit AFTO Form 22 (Technical Order System Publication Improvement Report and Reply) in accordance with paragraph 6-5, Section VI, T.O. 00-5-1. Forward direct to prime ALC/MST.

For Navy, mail comments to the Commander, Naval Electronics Systems Command, ATTN: ELEX 8122, Washington, DC 20360.

In either case, a reply will be furnished direct to you.

This manual is an authentication of the manufacturer's commercial literature which, through usage, has been found to cover the data required to operate and maintain this equipment. Since the manual was not prepared in accordance with military specifications and AR 310-3, the format has not been structured to consider levels of maintenance.

TABLE OF CONTENTS

Section	Page No.	Section	Page No.	
I	GENERAL INFORMATION	3 - 3	Operating Modes	3-1
1-A.1	Scope	3 - 5	Normal Operating Mode	3-1
1-A.3	Index of Publications	3 - 7	Constant Voltage	3-1
1-A.4	Army	3 - 9	Constant Current	3-2
1-A.6	Air Force	3-11	Connecting Load	3-2
1-A.8	Maintenance Forms, Records and Reports	3-14	Operation of Supply Beyond Rated Output	3-2
1-A.9	Reports of Maintenance and Unsatisfactory Equipment	3-16	Optional Operational Modes	3-2
1-A.11	Report of Packaging and Handling Deficiencies	3-17	Remote Programming, Constant Voltage	3-2
1-A.13	Discrepancy in Shipment Report (DISREP) (SF 361)	3-24	Remote Programming Constant Current	3-3
1-A.15	Reporting Equipment Improvement Recommendations (EIR)	3-30	Remote Sensing	3-4
1-A.18	Air Force	3-35	Series Operation	3-4
1-A.20	Navy	3-39	Parallel Operation	3-5
1-A.22	Administrative Storage	3-42	Auto-Tracking Operation	3-6
1-A.24	Destruction Of Army Electronics Materiel	3-45	Special Operating Consid- erations	3-6
1-1	Description	3-46	Pulse Loading	3-6
1-6	Specifications	3-48	Output Capacitance	3-6
1-8	Options	3-51	Reverse Voltage Loading	3-7
1-10	Instrument Identifica- tion	3-53	Reverse Current Loading	3-7
1-13	Ordering Additional Manuals	3-55	Overvoltage Protection Crowbar	3-7
II	INSTALLATION	IV	PRINCIPLES OF OPERATION	4-1
2-1	Initial Inspection	4-1	Overall Block Diagram Discussion	4-1
2-3	Mechanical Check	4-5	Simplified Schematic	4-2
2-5	Electrical Check	4-8	Detailed Circuit Analysis	4-3
2-7	Installation Data	4-9	Feedback Loop	4-3
2-9	Location	4-14	Series Regulator	4-3
2-11	Rack Mounting	4-16	Constant Voltage Input Circuit	4-3
2-13	Input Power Requirements	4-20	Constant Current Input Circuit	4-4
2-15	Connections for 230 Volt Operation	4-25	Voltage Clamp Circuit	4-4
2-17	Power Cable	4-28	Mixer and Error Amplifiers	4-4
2-20	Repackaging for Shipment	4-31	Reference Circuit	4-5
III	OPERATING INSTRUCTIONS	4-34	Meter Circuit	4-5
3-1	Operating Controls and Indicators	V	MAINTENANCE	5-1
		5-1	Introduction	5-1
		5-3	General Measurement Techniques	5-1
		5-8	Test Equipment Required	5-2

TABLE OF CONTENTS (CONTINUED)

Section	Page No.	Section	Page No.
5-10	5-2	5-47A.29 Silicon Rectifier	
5-12	5-2	CR19 Replacement	5-20
5-34	5-8	5-47A.31 Meter Switch S2	
		Replacement	5-21
5-39	5-9	5-47A.33 Meter Replacement	5-21
5-41	5-9	5-47A.35 Shunt Resistor	
5-46	5-14	(R81, R82, or R83)	
		Replacement	5-21
5-47A.1	5-15	5-47A.37 Fuse Holder Assembly	
5-47A.3	5-15	Replacement	5-21
5-47A.5	5-17	5-47A.39 Neon Lamp DS1	
		Replacement	5-21
5-47A.7	5-17	5-47A.41 Crowbar Adjust	
		Potentiometer R5	
5-47A.9	5-17	Replacement	5-22
5-47A.11	5-17	5-48 Adjustment and	
		Calibration	5-22
	5-18	5-50 Meter Zero.	5-22
		5-52 Voltmeter Tracking	5-22
		5-54 Ammeter Tracking	5-22
		5-56 Constant Voltage	
		Programming Current	5-22
		5-59 Constant Current	
		Programming Current	5-23
		5-62 Reference Circuit	
		Adjustments	5-23
		5-64 Constant Voltage	
		Transient Response	5-23
	5-19	VI REPLACEABLE PARTS	6-1
		6-1 Introduction	6-1
		6-4 Ordering Information	6-1
	5-19	APPENDIX A	A-1
		APPENDIX B	B-1
		APPENDIX C	C-1
		APPENDIX D	D-1
		APPENDIX E	E-1
	5-20	INDEX	Index 1

LIST OF ILLUSTRATIONS

Figure		Page No.	Figure		Page No.
1-1	DC Power Supply	v	4-3	Voltmeter Connections, Simplified Schematic	4-5
2-1	Primary Connections	2-1	4-4	Ammeter Connections, Simplified Schematic	4-5
3-1	Front Panel Control and Indicators	3-1	5-1	Front Panel Terminal Connections	5-1
3-2	Normal Strapping Pattern	3-1	5-2	Output Current Measurement Technique	5-1
3-3	Remote Resistance Programming (Constant Voltage)	3-2	5-3	Differential Voltmeter Substitute Test Setup	5-2
3-4	Remote Voltage Programming (Constant Voltage)	3-3	5-4	Output Current, Test Setup	5-2
3-5	Remote Resistance Programming (Constant Current)	3-3	5-5	Load Regulation, Constant Voltage Test Setup	5-4
3-6	Remote Voltage Programming (Constant Current)	3-3	5-6	CV Ripple and Noise Test Setup	5-4
3-7	Remote Sensing	3-4	5-7	CV Noise Spike Test Setup	5-6
3-8	Normal Series Connections	3-4	5-8	Transient Response Test Setup	5-6
3-9	Auto-Series, Two and Three Units	3-5	5-9	Transient Response, Waveforms	5-6
3-10	Normal Parallel, Connections	3-5	5-10	CV Programming, Speed, Test Setup	5-7
3-11	Auto-Parallel, Two and Three Units	3-5	5-11	Output Impedance, Test Setup	5-7
3-12	Auto-Tracking, Two and Three Units	3-6	5-12	CC Ripple and Noise Test Setup	5-8
3-13	Model 6255A and 6289A Overvoltage Protection Crowbar	3-8	5-13	Servicing Printed Wiring Boards	5-13
4-1	Overall Block Diagram	4-1	5-14	Model 6255A Modular Cabinet	5-16
4-2	Simplified Schematic	4-2	FO-1	6255A Schematic	
			FO-2	Parts Location/Interconnection Diagram	

LIST OF TABLES

Table		Page No.	Table		Page No.
1-1	Specifications	1-4	5-6	Selected Semiconductor Characteristics	5-14
5-1	Test Equipment Required	5-3	5-7	Checks and Adjustments After Replacement of Semiconductor Devices	5-14
5-2	Common Troubles	5-9	5-8	Calibration and Adjustment Summary	5-15
5-3	Reference, Bias, and Troubleshooting	5-11			
5-4	Low Output Voltage Troubleshooting	5-11			
5-5	High Output Voltage Troubleshooting	5-12			

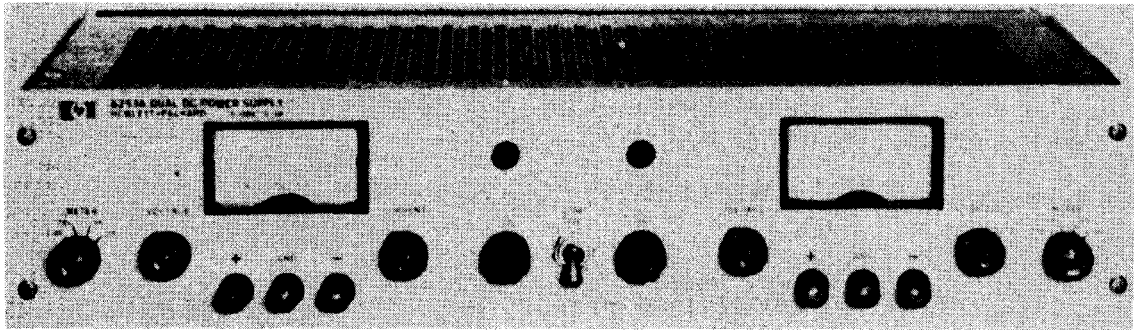

Figure 1-1. Typical DPR Series DC Power Supply

SECTION I
GENERAL INFORMATION

1-A.1 SCOPE

1-A.2 This manual describes the Model 6255A Dual DC Power Supply with Option 11 Overvoltage Protection Crowbar Circuit (power supply serial numbers 2012A-4996 and up). Responsibilities for all levels of maintenance are specified by the Maintenance Allocation Chart (MAC) contained in Appendix B.

1-A.3 INDEX OF PUBLICATIONS

1-A.4 ARMY

1-A.5 Refer to the latest issue of DA PAM 310-1 to determine whether there are new editions, changes or additional publications pertaining to the equipment.

1-A.6 AIR FORCE

1-A.7 Use T.O. 0.1-31 Series Numerical Index and Requirements Table (NIRT)

1-A.8 MAINTENANCE FORMS, RECORDS AND REPORTS

1-A.9 REPORTS OF MAINTENANCE AND UNSATISFACTORY EQUIPMENT

1-A.10 Department of the Army forms and procedures used for equipment maintenance will be those prescribed by TM 38-750, The Army Maintenance Management System (Army). Air Force personnel will use AFM 66-1 for maintenance reporting and T.O. 00-35D54 for unsatisfactory equipment reporting. Navy personnel will report maintenance performed utilizing the Maintenance Data Collection Subsystem (MDCS) IAW OPNAVINST 4790.2, Vol 3, and unsatisfactory material/conditions (UR submissions) IAW OPNAVINST 4790.2, Vol 2, chapter 17.

1-A.11 REPORT OF PACKAGING AND HANDLING DEFICIENCIES

1-A.12 Fill out and forward SD 364 (Report of Discrepancy (ROD) as prescribed in AR 735-11-2/DLAR 4140.55/NAVMATINST 4355.73/AFR 400-54/MCO 4430.3E.

1-A.13 DISCREPANCY IN SHIPMENT REPORT (DISREP) (SF 361)

1-A.14 Fill out and forward Discrepancy in Shipment Report (DISREP) (SF 361) as prescribed in AR 55-38/NAVSUPINST 4610.33B/AFR 75-18/MCO P4610.19C/DLAR 4500.15.1-4.

1-A.15 REPORTING EQUIPMENT IMPROVEMENT RECOMMENDATIONS (EIR)

1-A.16 ARMY

1-A.17 If the Power Supply, Dual DC needs improvement, let us know. Send us an EIR. You, the user, are the only one who can tell us what is not liked about your equipment. Let us know why you do not like the design. Tell us why a procedure is hard to perform. Put it on an SF 368 (Quality Deficiency Report). Mail it to Commander, US Army Communications-Electronics Command and Fort Monmouth, ATTN: DRSEL-ME-MP, Fort Monmouth, NJ 07003. We will send you a reply. reply

1-A.18 AIR FORCE

1-A.19 Air Force personnel are encouraged to submit EIRs in accordance with AFM 900-4.

1-A.20 NAVY

1-A.21 Navy personnel are encouraged to submit EIRs through their local Beneficial Suggestion Program.

1-A.22 ADMINISTRATIVE STORAGE

1-A.23 Refer to TM 11-5805-683-12 or

TM 11-5805-681-12, Administrative Storage. Administrative storage of equipment issued to and used by Army activities will have preventive maintenance performed in accordance with the Preventive Maintenance Checks and Services (PMCS) procedure listed before storing. When removing the equipment from administrative storage, PMCS should be performed to assure operational readiness. Disassembly and repacking of equipment for shipment or limited storage are also covered. Refer to TM 749-90-1 if there are no published PM char

1-A.24 DESTRUCTION OF ARMY ELECTRONICS MATERIEL

1-A.25 Destruction of Army electronics materiel to prevent enemy use shall be in accordance with TM 750-244-2.

1-1 DESCRIPTION

1-2 This power supply, Figure 1-1, is completely transistorized and suitable for either rack or bench operation. It is a dual supply consisting of two independently controlled sections; both identical to each other. These sections will be referred to as the left and right side power supplies as viewed from front of unit. Each section is a well-regulated, Voltage/Constant Current source that will furnish full rated output voltage at the maximum rated output current or can be continuously adjusted throughout either output range. The front panel CURRENT controls can be used to establish the output current limit (overload or short circuit) when the supply is used as a constant voltage source and the VOLTAGE control(s) can be used to establish the voltage limit (ceiling) when the supply is used as a constant current source. Each section will automatically cross-over from constant voltage to constant current operation and vice versa if the output current or voltage exceeds these preset limits.

1-3 Each supply has both front and rear terminals, terminals. Either the positive or negative output terminal may be grounded or the power supply can be operated floating at up to a maximum of 300 volts off ground, ground.

1-4 Each section has its own front panel meter and operating controls. The meters are of the multiple range type and can measure output voltage or current. The voltage or current ranges are selected by the applicable METER switch on the front panel.

1-5 TWO sets of programming terminals located at the rear of the unit allow ease in adapting to the many operational capabilities of the power supply. A brief description of these capabilities is given below:

a. Remote Programming

The power supply may be programmed from a remote location by means of an external voltage source or resistance.

b. Remote Sensing

The degradation in regulation which would occur at the load because of the voltage drop in the load leads can be reduced by using the power supply in the remote sensing mode of operation.

c. Series and Auto-Series Operation

Power supplies may be used in series when a higher output voltage is required in the voltage mode of operation or when greater voltage compliance is required in the constant current mode of operation. Auto-Series operation permits one knob control of the total output voltage from a "master" supply.

d. Parallel and Auto-Parallel Operation

The power supply may be operated in parallel with a similar unit when greater output current capability is required. Auto-Parallel operation permits one knob control of the total output current from a "master" supply.

e. Auto-Tracking

The power supply may be used as a "master" supply, having control over one (or more) "slave" supplies that furnish various voltages for a system.

1-6 SPECIFICATIONS

1-7 Detailed specifications for the power supply

are given in Table 1-1.

NOTE

Since both sections of this supply are identical, only one section will be discussed throughout the remaining portions of this manual. All descriptions, illustrations, tests, and adjustments apply equally to both sections of the supply.

Trip Voltage Margin: The minimum crowbar trip setting above the desired operating output voltage to prevent false crowbar tripping is 4% of the output voltage setting +2V.

Refer to Paragraph 3-55 for details of operation and Figure 3-13 for the schematic diagram.

1-8 OPTIONS

1-9 Options are factory modifications of a standard instrument that are requested by the customer. The following options are available for the instrument covered by this manual. Where necessary, detailed coverage of the options is included throughout the manual.

Option No. Description

- 07 Voltage 10-Turn Pot: A single control that replaces both coarse and fine voltage controls and improves output settability. Standard item on Model 6258A power supplies.
- 08 Current 10-Turn Pot: A single control that replaces both coarse and fine current controls and improves output settability.
- 09 Voltage and Current 10-Turn Pot: Consists of Options 07 and 08 on the same instrument.
- 10 Chassis Slides: Enables convenient access to power supply interior for maintenance purposes.
- 11 Internal Overvoltage Protection "Crowbars": This option includes two crowbar circuits, one for each power supply within the 6253A or 625. Each crowbar protects delicate loads by monitoring the output voltage and firing an SCR that shorts the output when the preset trip voltage is exceeded. The circuit boards are factory installed within the supply. The "Crowbar Adjust" controls are mounted on the front panel to permit convenient adjustment.

Trip Voltage Range:

<u>6253A</u>	<u>6255A</u>
2.5 to 23V	2.5 to 44V

- 13 Three Digit Graduated Decadal Voltage Control: Control that replaces coarse and fine voltage controls permitting accurate resettability.
- 14 Three Digit Graduated Decadal Current Control: Control that replaces coarse and fine current controls permitting accurate resettability.
- 28 Rewire for 230V AC Input: Supply as normally shipped is wired for 115VAC input. Option 28 consists of reconnecting the input transformer for 230V AC operation.

1-10 INSTRUMENT IDENTIFICATION

1-11 Hewlett-Packard power supplies are identified by a three-part serial number tag. The first part is the power supply model number. The second part is the serial number prefix, which consists of a number-letter combination that denotes the date of a significant design change. The number designates the year, and the letter A through L designates the month, January through December, respectively. The third part is the power supply serial number.

1-12 If the serial number prefix on your power supply does not agree with the prefix on the title page of this manual, change sheets are included to update the manual. Where applicable, backdating information is given in an appendix at the rear of the manual.

1-13 ORDERING ADDITIONAL MANUALS

1-14 One manual is shipped with each power supply. Additional manuals may be obtained from regular publication distribution channels.

Table 1-1. Specifications

<p>INPUT: 105-125 VAC, single phase, 50-400 cps.</p> <p>OUTPUT: Two independent outputs each of which can be set at 0-40 volts @ 0-1. amps.</p> <p>LOAD REGULATION: Constant Voltage -- Less than 0. plus 2mv for a full load to no load change in output current. Constant Current -- Less than 0. plus 25 for a zero to maximum change in output voltage.</p> <p>LINE REGULATION: Constant Voltage -- Less than 0. plus 2mv for any line voltage change within the input rating. Constant Current -- Less than 0. plus 25 for any line voltage change within the input rating.</p> <p>RIPPLE AND NOISE: Constant Voltage -- Less than 200μv rms. Constant Current -- Less than 500μa rms.</p> <p>TEMPERATURE RANGES: Operating: 0 to 5 Storage: -20 to +85°C.</p> <p>TEMPERATURE COEFFICIENT: Constant Voltage -- Less than 0. plus 500μv per degree Centigrade. Constant Current -- Less than 0. plus 0. per degree Centigrade.</p> <p>STABILITY: Constant Voltage -- Less than 0. plus 2. total drift for 8 hours after an initial warm-up time of 30 minutes at constant ambient, constant line voltage, and constant load. Constant Current -- Less than 0. plus 4ma total drift for 8 hours after an initial warm-up time of 30 minutes at constant ambient, constant line voltage, and constant load.</p> <p>OUTPUT IMPEDANCE (</p> <p>Approximated by a 10 mi resistance in series with a 1 microhenry inductance.</p> <p>TRANSIENT RECOVERY TIME: Less than 5 for output recovery to within 15 mv following a full load current change in the output.</p>	<p>OVERLOAD PROTECTION: A continuously acting constant current circuit protects the power supply for all overloads including a direct short placed across the terminals in constant voltage operation. The constant voltage circuit limits the output voltage in the constant current mode of operation.</p> <p>METERS: Each front panel meter can be used as either a 0-50V or 0-5 volt voltmeter or as a 0-1. or 0-0. amp ammeter.</p> <p>OUTPUT CONTROLS: Coarse and fine voltage controls and coarse and fine current controls set desired output voltage or current.</p> <p>OUTPUT TERMINALS: Six output posts (three per section) are provided on the front panel and output terminal strips are located on the rear of the chassis. All power supply output terminals are isolated from the chassis and either the positive or negative terminals may be connected to the chassis through a separate ground terminal located on the output terminal strip.</p> <p>ERROR SENSING: Error sensing is normally accomplished at the front terminals if the load is attached to the front or at the rear terminals if the load is attached to the rear terminals. Also, provision is included on the rear terminal strip for remote sensing.</p> <p>REMOTE PROGRAMMING: Remote programming of the supply output at approximately 200 ohms per volt in constant voltage is made available at the rear terminals. In constant current mode of operation, the current can be remotely programmed at approximately 500 ohms per ampere.</p> <p>COOLING: Convection cooling is employed. The supply has no moving parts.</p> <p>SIZE: 3- 1/2" H x 14- 1/2" D x 19" W. Easily rack mounted in a standard 19" relay rack.</p> <p>WEIGHT: 28 lbs. net, 35 lbs. shipping.</p> <p>FINISH: Light gray front panel with dark gray case.</p> <p>POWER CORD: A three-wire, five-foot power cord is provided with each unit.</p>
---	---

SECTION II
INSTALLATION

2-1 INITIAL INSPECTION

2-2 Before shipment, this instrument was inspected and found to be free of mechanical and electrical defects. As soon as the instrument is unpacked, inspect for any damage that may have occurred in transit. Save all packing materials until the inspection is completed.

2-3 MECHANICAL CHECK

2-4 This check should confirm that there are no broken knobs or connectors, that the cabinet and panel surfaces are free of dents and scratches, and that the meter is not scratched or cracked.

2-5 ELECTRICAL CHECK

2-6 The instrument should be checked against its electrical specifications. Section V includes an "in-cabinet" performance check to verify proper instrument operation.

2-7 INSTALLATION DATA

2-8 The instrument is shipped ready for bench operation. It is necessary only to connect the instrument to a source of power and it is ready for operation.

2-9 LOCATION

2-10 This instrument is air cooled. Sufficient space should be allotted so that a free flow of cooling air can reach the sides and rear of the instrument when it is in operation. It should be used in an area where the ambient temperature does not exceed 50°C.

2-11 RACK MOUNTING

2-12 This instrument is full rack size and can be easily rack mounted in a conventional 19 inch rack panel using standard mounting screws.

2-13 INPUT POWER REQUIREMENTS

2-14 This power supply may be operated from

either a nominal 115 volt or 230 volt 50-400 cycle power source. The unit, as shipped from the factory, is wired for 115 volt operation. The input power required when operated from a 115 volt 60 cycle power source at full load is 235 watts and 2.6 amperes.

2-15 CONNECTIONS FOR 230 VOLT OPERATION
(Figure 2-1)

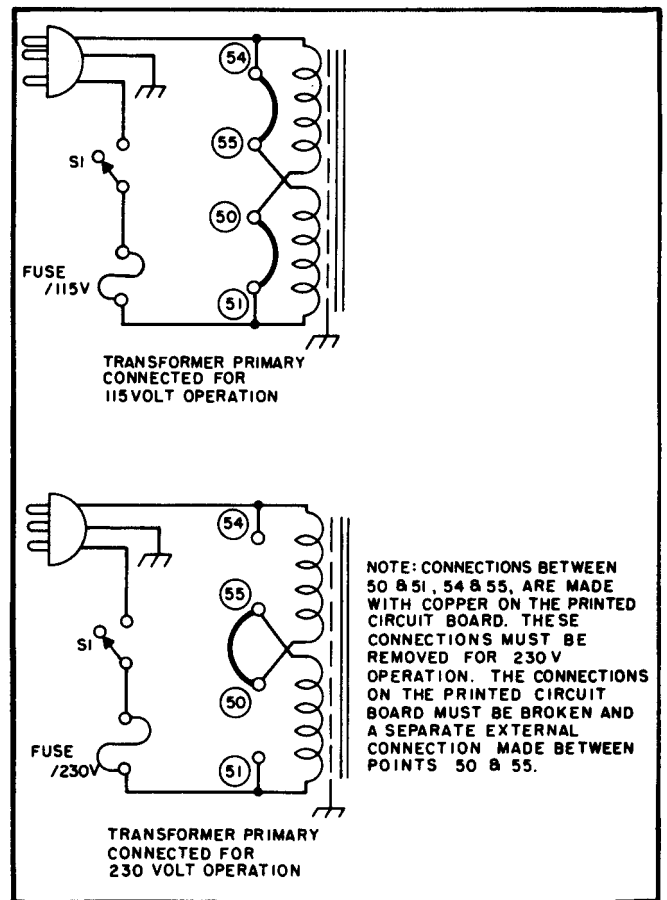

Figure 2-1. Primary Connections

2-16 Normally, the two primary windings of the input transformer are connected in parallel for operation from 115 volt source. To convert the power supply to operation from a 230 volt source, the power transformer windings are connected in series as follows:

- a. Unplug the line cord and remove the unit covers.
- b. Break the copper between 54 and 55 and also between 50 and 51 on the printed circuit board. These are shown in Figure 2-1, and are labeled on copper side of printed circuit board.
- c. Add strap between 50 and 55.
- d. Replace existing fuse with 2 ampere, 230 volt fuse. Return unit to case and operate normally.

2-17 POWER CABLE

2-18 To protect operating personnel, National Electrical Manufacturers Association recommends that the instrument panel and cabinet be grounded. This instrument is equipped with a three conductor power cable. The third conductor is the ground conductor and when the cable is plugged into an appropriate receptacle, the instrument is grounded. The offset pin on the power

cable three-prong connector is the ground connection.

2-19 To preserve the protection feature when operating the instrument from a two-contact outlet, use a three-prong to two-prong adapter and connect the green lead on the adapter to ground.

2-20 REPACKAGING FOR SHIPMENT

2-21 To insure safe shipment of the instrument, it is recommended that the package designed for the instrument be used. The original packaging material is reusable.

SECTION III
OPERATING INSTRUCTIONS

3-1 OPERATING CONTROLS AND INDICATORS

3-2 The front panel controls and indicators, together with the normal turn-on sequence, are shown in Figure 3-1.

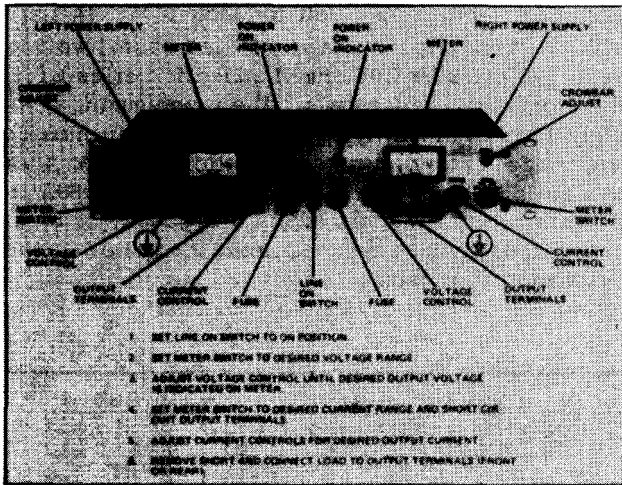

Figure 3-1. Front Panel Controls and Indicators

3-3 OPERATING MODES

3-4 The power supply is designed so that its mode of operation can be selected by making strapping connections between particular terminals on the terminal strip at the rear of the power supply. The terminal designations are stenciled in white on the power supply above their respective terminals.

WARNING

Dangerous voltages exist in this equipment. Be careful when working with the power supplies and their circuits.

Although the strapping patterns illustrated in this section show the positive terminal grounded, the operator can ground either terminal or operate the power supply up to 300Vdc off ground. The following para-

graphs describe the procedures for utilizing the various operational capabilities of the power supply. A more theoretical description concerning the operational features of this supply is contained in Application Note 90, DC Power Supply Handbook.

3-5 NORMAL OPERATING MODE

3-6 The power supply is normally shipped with its rear terminal strapping connections arranged for Constant Voltage/Constant Voltage/Constant Current, local sensing, local programming, single unit mode of operation. This strapping pattern is illustrated in Figure 3-2. The operator selects either a constant voltage or a constant current output using the front panel controls (local programming, no strapping changes are necessary).

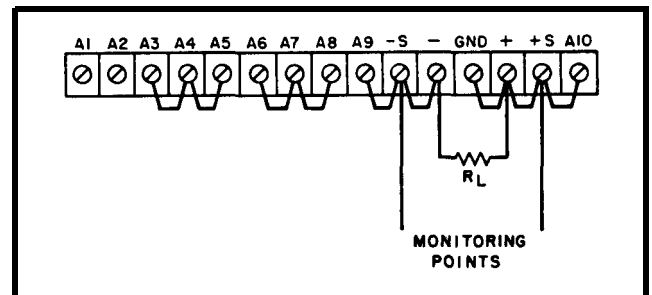

Figure 3-2. Normal Strapping Pattern

3-7 **CONSTANT VOLTAGE** (See Figure 3-1 for controls and indicators).

3-8 To select a constant voltage output, proceed as follows:

a. Turn-on power supply and adjust VOLTAGE controls for desired output voltage (output terminals open).

b. Short output terminals and adjust CURRENT controls for maximum output current allowable (current limit), as determined by load conditions. If a load change causes the current limit to be exceeded, the power supply will automatically cross-over to constant current output at the preset current limit and the output voltage will drop proportionately. In setting the current limit, allowance must be made for high peak current which can cause unwanted cross-over. (Refer to Paragraph 3-46.)

3-9 **CONSTANT CURRENT** (See Figure 3-1 for controls and indicators.)

3-10 To select a constant current output, proceed as follows:

- a. Short output terminals and adjust CURRENT controls for desired output current.
- b. Open output terminals and adjust VOLTAGE controls for maximum output voltage allowable (voltage limit), as determined by load conditions. If a load change causes the voltage limit to be exceeded, the power supply will automatically crossover to constant voltage output at the preset voltage limit and the output current will drop proportionately. In setting the voltage limit, allowance must be made for high peak voltages which can cause unwanted crossover. (Refer to Paragraph 3-46.)

3-11 **CONNECTING LOAD** (See Figure 3-1 for output terminals.)

3-12 Each load should be connected to the power supply output terminals using separate pairs of connecting wires. This will minimize mutual coupling effects between loads and will retain full advantage of the low output impedance of the power supply. Each pair of connecting wires should be as short as possible and twisted or shielded to reduce noise pickup. (If shield is used, connect one end to power supply ground terminal and leave the other end unconnected.)

3-13 If load considerations require that the output power distribution terminals be remotely located from the power supply, then the power supply output terminals should be connected to the remote distribution terminals via a pair of twisted or shielded wires and each load separately connected to the remote distribution terminals. For this case, remote sensing should be used (Paragraph 3-20).

3-14 **OPERATION OF SUPPLY BEYOND RATED OUTPUT**

3-15 The shaded area on the front panel meter face indicates the amount of output voltage or current that is available in excess of the normal rated output. Although the supply can be operated in this shaded region without being damaged, it cannot be guaranteed to meet all of its performance specifications. However, if the line voltage is maintained above 115 Vac, the supply will probably operate within its specifications.

3-16 **OPTIONAL OPERATING MODES**

3-17 **REMOTE PROGRAMMING, CONSTANT VOLTAGE**

3-18 The constant voltage output of the power supply can be programmed (controlled) from a remote location if required. Either a resistance or voltage

source can be used for the programming device. The wires connecting the programming terminals of the supply to the remote programming device should be twisted or shielded to reduce noise pick-up. The VOLTAGE controls on the front panel are disabled according to the following procedures.

3-19 **Resistance Programming** (Figure 3-3). In this mode, the output voltage will vary at a rate determined by the programming coefficient (200 ohms per Volt for Models 6253A, 6255A, 6281A, 6284A, and 6289A or 300 ohms per Volt for Models 6294A and 6299A). The output voltage will increase 1 Volt for each 200 ohms (or 300 ohms) added in series with the programming terminals. The programming coefficient is determined by the programming current. This current is factory adjusted to within 2% of 5mA for Models 6253A, 6255A, 6281A, 6284A, and 6289A or 2% of 3.3mA for Models 6294A and 6299A. If greater programming is required, it may be achieved by changing resistor R 13.

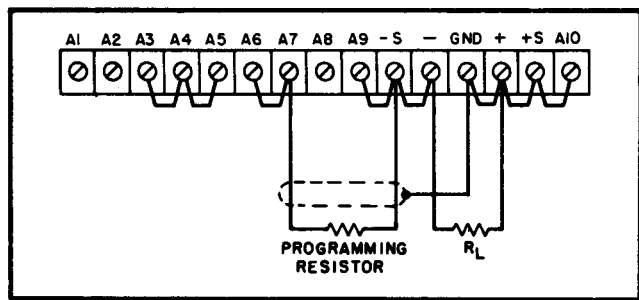

Figure 3-3. Remote Resistance Programming (Constant Voltage)

3-20 The output voltage of the power supply should be zero Volts ± 20 millivolts when zero ohms is connected across the programming terminals. If a zero ohm voltage closer than this is required, it may be achieved by changing resistor R6 or R8 as described in Paragraph 5-59.

3-21 To maintain the stability and temperature coefficient of the power supply, use programming resistors that have stable, low noise, and low temperature (less than 30 ppm per degree Centigrade)

A switch can be used in conjunction with various resistance values in order to obtain discrete output voltages. The switch should have make-before-break contacts to avoid momentarily opening the programming terminals during the switching interval.

3-22 Voltage Programming (Figure 3-4). Employ the strapping pattern shown on Figure 3-4 for

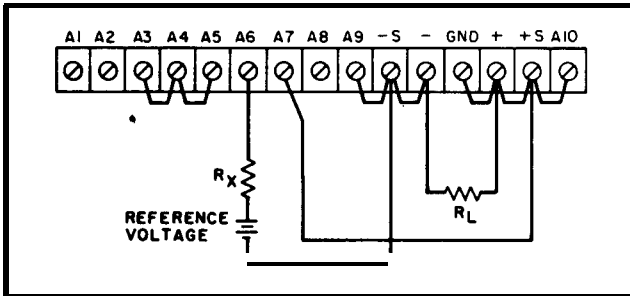

Figure 3-4. Remote Voltage Programming (Constant Voltage)

voltage programming. In this mode, the output voltage will vary in a 1 to 1 ratio with the programming voltage (reference voltage) and the load on the programming voltage source will not exceed 25mA.

3-23 The impedance matching resistor (Rx) for the programming voltage source should be approximately 500 ohms to maintain the temperature and stability specifications of the power supply.

3-24 **REMOTE PROGRAMMING, CONSTANT CURRENT (See Figure 3-1 for controls and indicators.)**

3-25 Either a resistance or a voltage source can be used to control the constant current output of the supply. The CURRENT controls on the front panel are disabled according to the following procedures.

3-26 Resistance Programming (Figure 3-5). In this mode, the output current varies at a rate determined by the programming coefficient — 200 ohms per Amp for Model 628 1A, 500 ohms per Ampere for Models 6253A, 6255A, 6284A, and 6289A, and 1000 ohms per Ampere for Models 6294A and 6299A. The programming coefficient is determined by the Constant Current programming current (2mA for Models 6253A, 6255A, 6284A, and 6289A, 5mA for Model 6281A, 1mA for Model 6294A and 1.33mA for Model 6299A). This current is adjusted to within 10% at the factory. If greater programming accuracy is required, it may be achieved by changing resistor R 19 as outlined in Section V.

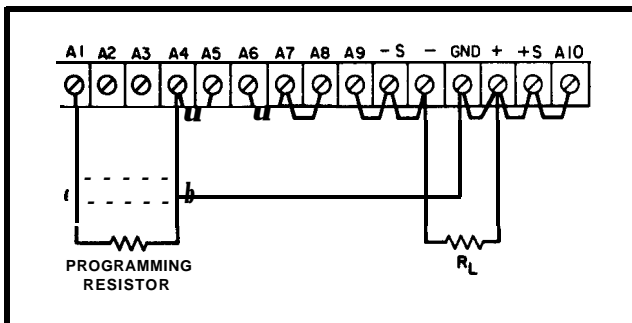

Figure 3-5. Remote Resistance Programming (Constant Current)

3-27 Use stable, low noise, low temperature coefficient (less than 3 0ppm/°C) programming resistors to maintain the power supply temperature coefficient and stability specifications. A switch may be used to set discrete values of output current. A make-before-break type of switch should be used since the output current will exceed the maximum rating of the power supply if the switch contacts open during the switching interval.

CAUTION

If the programming terminals (A1 and A5) should open at any time during this mode, the output current will rise to a value that may damage the power supply and/or the load. To avoid this possibility, connect a resistor across the programming terminals having the value listed below. Like the programming resistor, this resistor should be of the low noise, low temperature coefficient type.

Model	6253 A, 6284A	6255 A, 6289A, 6299A
Resistance	1.5K Ω	750 Ω

Model	6281A, 6294A
Resistance	1K Ω

3-28 Voltage Programming (Figure 3-6). In this mode, the output current will vary linearly with changes in the programming voltage. The programming voltage should not exceed 1.2 Volts. Voltage in excess of 1.2 Volts will result in excessive power dissipation in the instrument and possible damage.

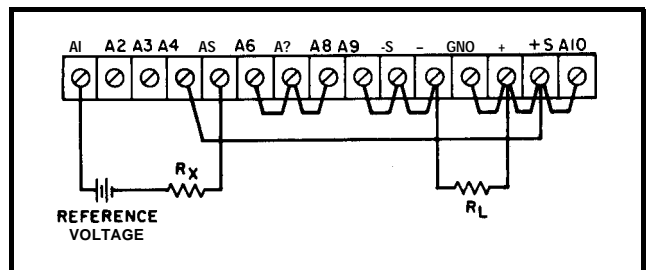

Figure 3-6. Remote Voltage Programming (Constant Current)

3-29 The output current will be the programming voltage divided by 1 ohm. The current required from the voltage source will be less than 25 micro-ampere. The impedance matching resistor (Rx) should be approximately 500 ohms if the temperature coefficient and stability specifications of the power supply are to be maintained.

3-30 REMOTE SENSING (See Figure 3-7)

3-31 Remote sensing is used to maintain good regulation at the load and reduce the degradation of regulation which would occur due to the voltage drop in the leads between the power supply and the load. Remote sensing is accomplished by utilizing the strapping pattern shown in Figure 3-7. The power supply should be turned off before changing strapping patterns. The leads from the +S terminals to the load will carry less than 10mA of current, and it is not required that these leads be as heavy as the load leads. However, they must be twisted or shielded to minimize noise pick-up.

CAUTION

Observe polarity when connecting the sensing leads to the load.

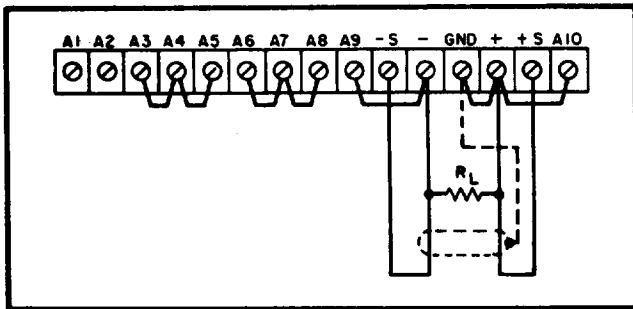

Figure 3-7. Remote Sensing

3-32 Note that it is desirable to minimize the drop in the load leads and it is recommended that the drop not exceed 1 Volt per lead if the power supply is to meet its dc specifications. If a larger drop must be tolerated, please consult a Hewlett-Packard field representative.

NOTE

Due to the voltage drop in the load leads, it may be necessary to readjust the current limit in the remote sensing mode.

3-33 The procedure just described will result in a low dc output impedance at the load. If a low ac impedance is required, it is recommended that the following precautions be taken:

- Disconnect output capacitor C20 by disconnecting the strap between A9 and -S.
- Connect a capacitor having similar characteristics (approximately same capacitance, same voltage rating or greater, and having good high frequency characteristics) across the load using short leads.

3-34 Although the strapping patterns shown in Figures 3-3 through 3-6 employ local sensing, note

that it is possible to operate a power supply simultaneously in the remote sensing and Constant Voltage/Constant Current remote programming modes.

3-35 SERIES OPERATION

3-36 Normal Series Connections (Figure 3-8). Two or more power supplies can be operated in series to obtain a higher voltage than that available from a single supply. When this connection is used, the output voltage is the sum of the voltages of the individual supplies. Each of the individual supplies must be adjusted in order to obtain the total output voltage. The power supply contains a protective diode connected internally across the output which protects the supply if one power supply is turned off while its series partner(s) is on.

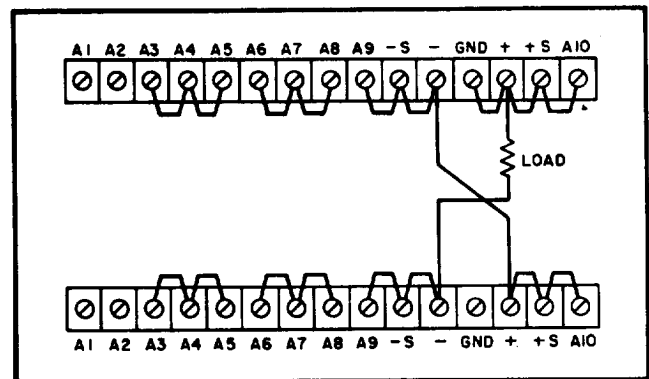

Figure 3-8. Normal Series Connections

3-37 Auto-Series Connections (Figure 3-9). The Auto-Series configuration is used when it is desirable to have the output voltage of each of the series connected supplies vary in accordance with the setting of a control unit. The control unit is called the master; the controlled units are called slaves. At maximum output voltage, the voltage of the slaves is determined by the setting of the front panel VOLTAGE control on the master. The master supply must be the most positive supply of the series. The output CURRENT controls of all series units are operative and the current limit is equal to the lowest control setting. If any output CURRENT controls are set too low, automatic crossover to constant current operation will occur and the output voltage will drop. Remote sensing and programming can be used; however, the strapping arrangements shown in the applicable figures show local sensing and programming.

3-38 In order to maintain the temperature coefficient and stability specifications of the power supply, the external resistors (Rx) shown in Figure 3-9 should be stable, low noise, low temperature coefficient (less than 30 ppm per degree Centigrade) resistors. The value of each resistor is dependant

on the maximum voltage rating of the "master" supply. The value of R_x is this voltage divided by the voltage programming current of the slave supply ($1/K_p$ where K_p is the voltage programming coefficient). The voltage contribution of the slave is determined by its voltage control setting.

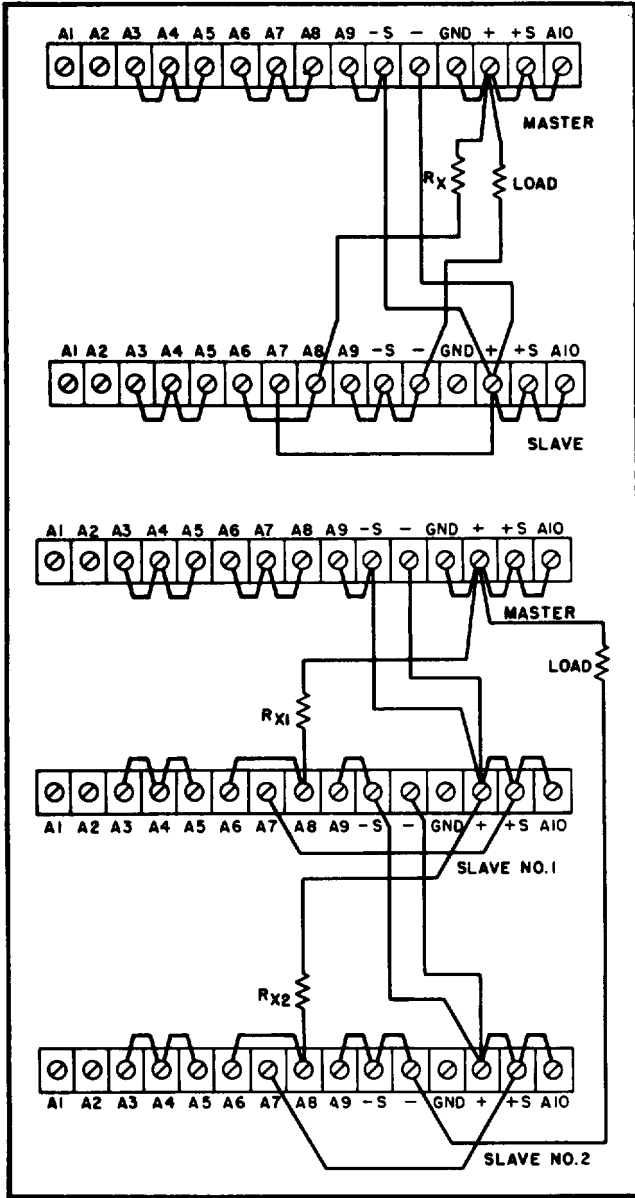

Figure 3-9. Auto-Series, Two and Three Units

3-39 PARALLEL OPERATION (See Figure 3-1 for controls and indicators.)

3-40 Normal Parallel Connections (Figure 3-10). Two or more power supplies can be connected in parallel to obtain a total output current greater than that available from one power supply. The total output current is the sum of the output currents of the individual power supplies. The output CURRENT

controls of each power supply can be separately set. The output voltage controls of one power supply should be set to the desired output voltage; the other power supply should be set for a slightly larger output volts ge. The supply set to the lower output voltage will act as a constant voltage source; the supply set to the higher output will act as a constant current source, dropping its output

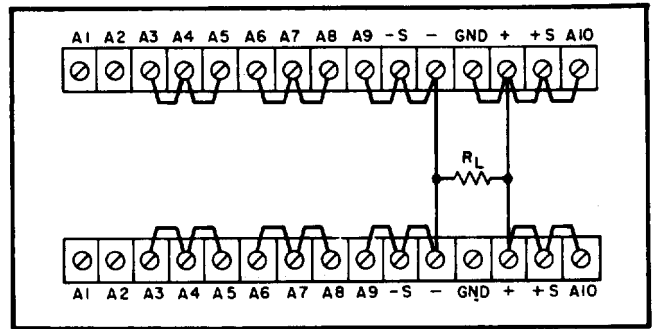

Figure 3-10. Normal Parallel Connections

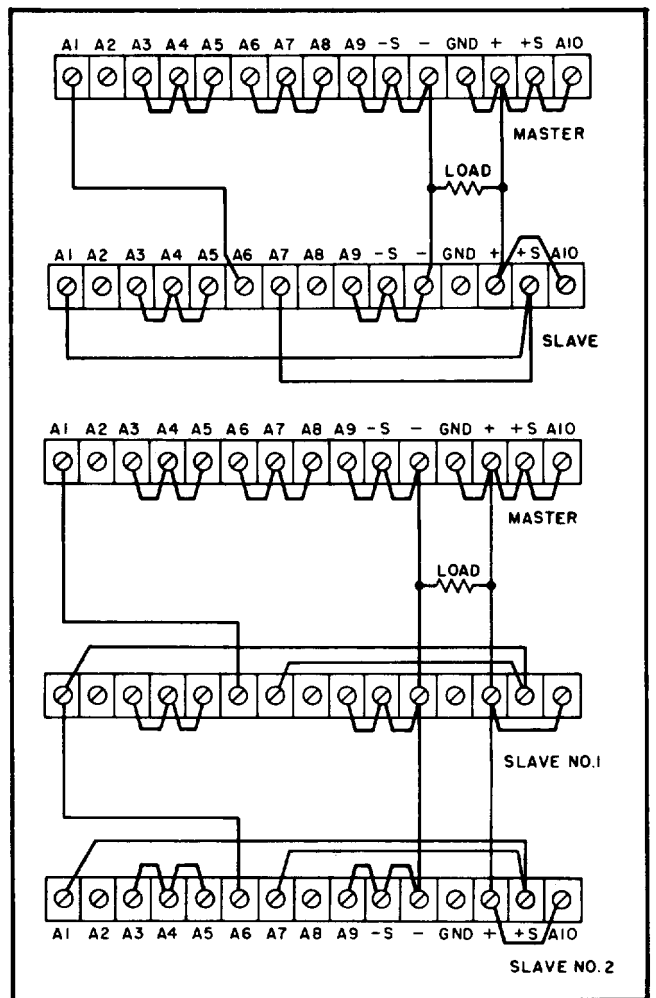

Figure 3-11. Auto-Parallel, Two and Three Units

voltage until it equals that of the other supply. The constant voltage source will deliver only that fraction of its total rated output current which is necessary to fulfill the total current demand.

3-41 Auto-Parallel. The strapping patterns for Auto-Parallel operation of two power supplies are shown in Figure 3-11. Auto-Parallel operation permits equal current sharing under all load conditions, and allows complete control of output current from one master power supply. The output current of each slave will be approximately equal to the master's regardless of the load conditions. Because the output current controls of each slave are operative, the y should be set to maximum to avoid having the slave revert to constant current operation; this would occur if the master output current setting exceeded the sla

3-42 AUTO-TRACKING OPERATION (See Figure 3-12)

3-43 The Auto-Tracking configuration is used when it is necessary that several different voltages referred to a common bus, vary in proportion to the setting of a particular instrument (the control or master). A fraction of the master's output voltage is fed to the comparison amplifier of the slave supply, thus controlling the slave's output. The master must have the largest output voltage of any power supply in the group (must be the most positive supply in the example shown on Figure 3-12).

3-44 The output voltage of the slave is a percentage of the ma output voltage, and is determined by the voltage divider consisting of R_X (or R_X and R_Y) and the voltage control of the slave supply, R_p . where: E_s = Turn-on and turn-off of the power supplies is controlled by the master. Remote sensing and programming can be used; although the strapping patterns for these modes show only local sensing and programming. In order to maintain the temperature coefficient and stability specifications of the power supply, the external resistors should be stable, low noise, low temperature (less than 30ppm per °C) resistors.

3-45 SPECIAL OPERATING CONSIDERATIONS

3-46 PULSE LOADING

3-47 The power supply will automatically crossover from constant voltage to constant current operation, or the reverse, in response to an increase (over the preset limit) in the output current or voltage, respectively. Although the preset limit may be set higher than the average output current or voltage, high peak currents or voltages (as occur in pulse loading) may exceed the preset limit and cause cros to occur. If this crossover limiting is not desired, set the preset limit for the peak requirement and not the average.

3-48 OUTPUT CAPACITANCE

3-49 An internal capacitor, connected across the output terminals of the power supply, helps to supply high-current pulses of short duration during constant voltage operation. Any capacitance added externally will improve the pulse current capability, but will decrease the safety provided by the constant current circuit. A high-current pulse may damage load components before the average output current is large enough to cause the constant current circuit to operate.

3-50 The effects of the output capacitor during constant current operation are as follows:

- a. The output impedance of the power supply

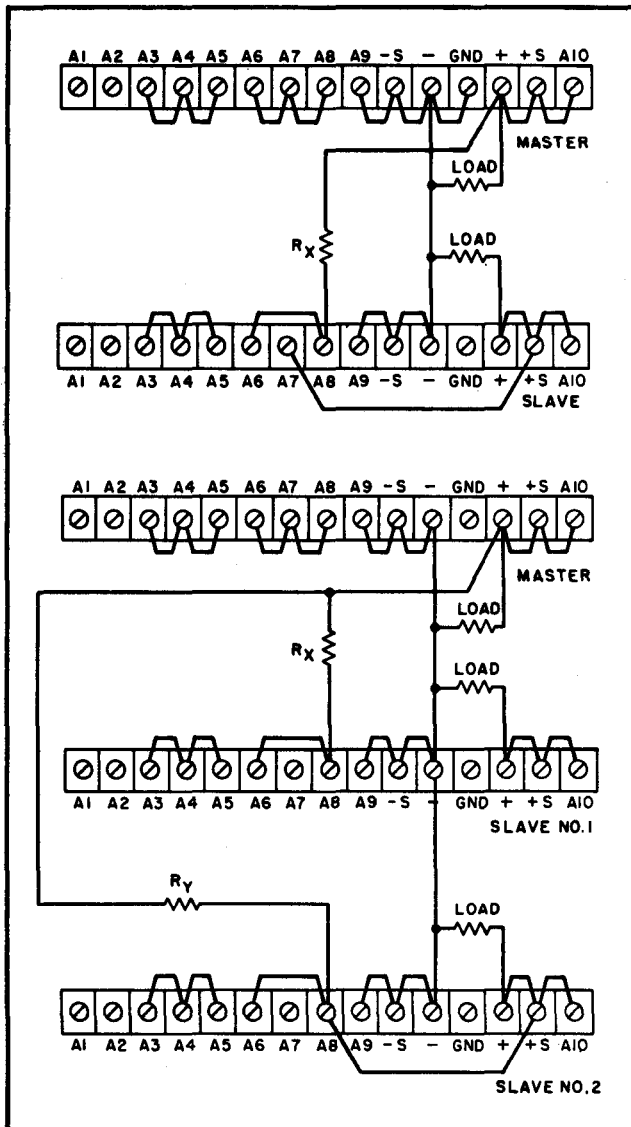

Figure 3-12. Auto-Tra Two and Three Units

decreases with increasing frequency.

b. The recovery time of the output voltage is longer for load resistance changes.

c. A large surge current causing a high power dissipation in the load occurs when the load resistance is reduced rapidly.

3-51 REVERSE VOLTAGE LOADING

3-52 A diode is connected across the output terminals. Under normal operating conditions, the diode is reverse biased (anode connected to negative terminal). If a reverse voltage is applied to the output terminals (positive voltage applied to negative terminal), the diode will conduct, shunting current across the output terminals and limiting the voltage to the forward voltage drop of the diode. This diode protects the series transistors and the output electrolytic capacitor.

3-53 REVERSE CURRENT LOADING

3-54 Active loads connected to the power supply may actually deliver a reverse current to the power supply during a portion of its operating cycle. An external source cannot be allowed to pump current into the supply without loss of regulation and possible damage to the output capacitor. To avoid these effects, it is necessary to preload the supply with a dummy load resistor so that the power supply delivers current through the entire operating cycle of the load device.

3-55 **OVERVOLTAGE PROTECTION CROWBAR**
(See Figure 3-1 for controls and indicators and Figure 3-13 for the schematic diagram.)

3-56 Use the following steps to adjust the crowbar circuit.

a. Turn CROWBAR ADJUST fully clockwise to set trip voltage to maximum.

b. Set power supply VOLTAGE control for desired crowbar trip voltage. To prevent false crowbar tripping, trip voltage should exceed desired output voltage by the following amount: 4% of the output voltage plus 2V

c. Slowly turn CROWBAR ADJUST ccw until crowbar trips, output goes to OV or a small positive voltage.

d. Crowbar will remain activated and output shorted until supply is turned off. To reset crowbar, turn supply off, then on.

e. If CROWBAR must be completely disabled, remove lead attached to CROWBAR ADJUST potentiometer R5.

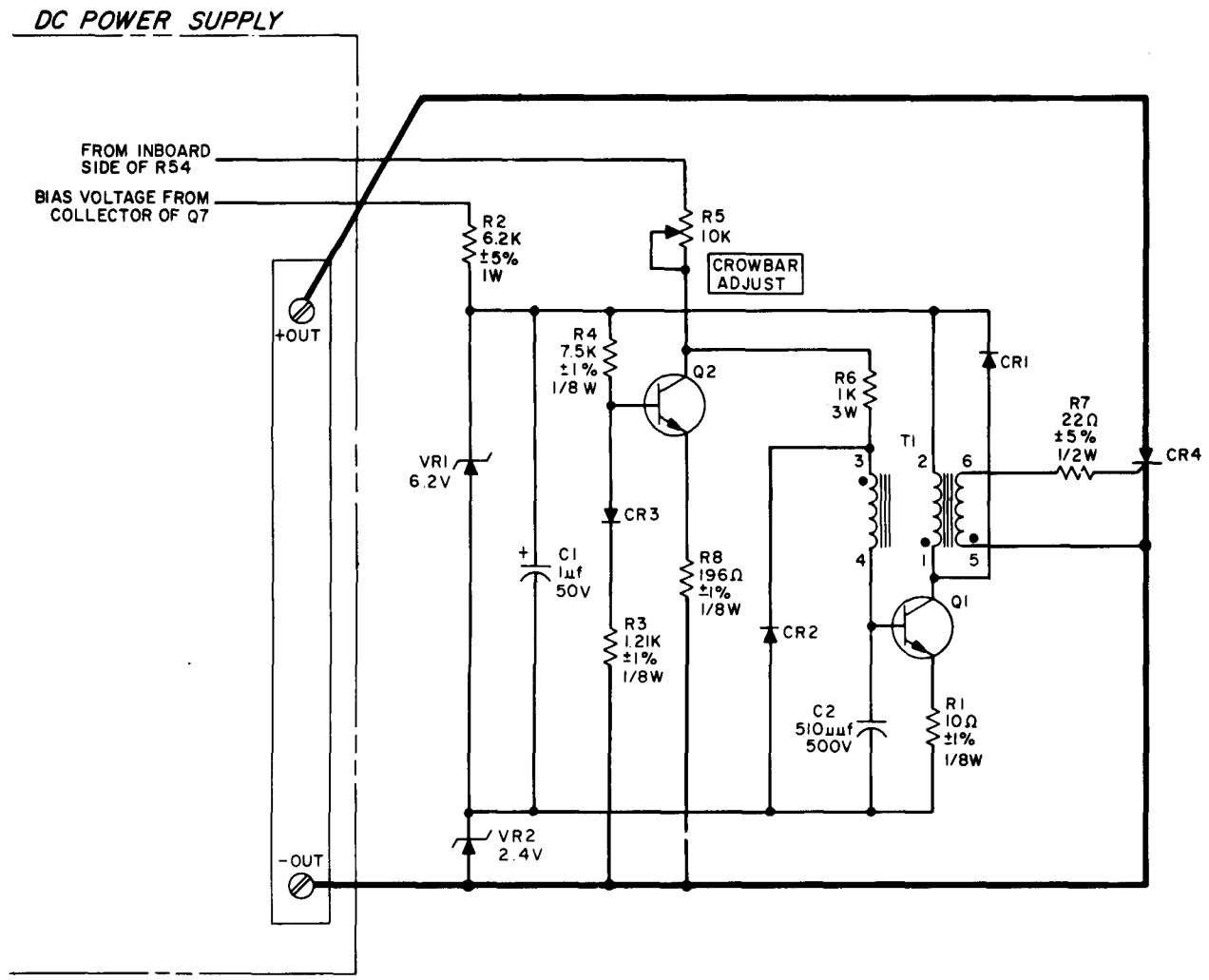

CIRCUIT PATENTS APPLIED FOR LICENSE TO USE MUST BE OBTAINED IN WRITING FROM HEWLETT-PACKARD CO. HARRISON DIVISION.

Figure 3-13. Model 6255A and 6289A Overvoltage Protection Crowbar

SECTION IV
PRINCIPLES OF OPERATION

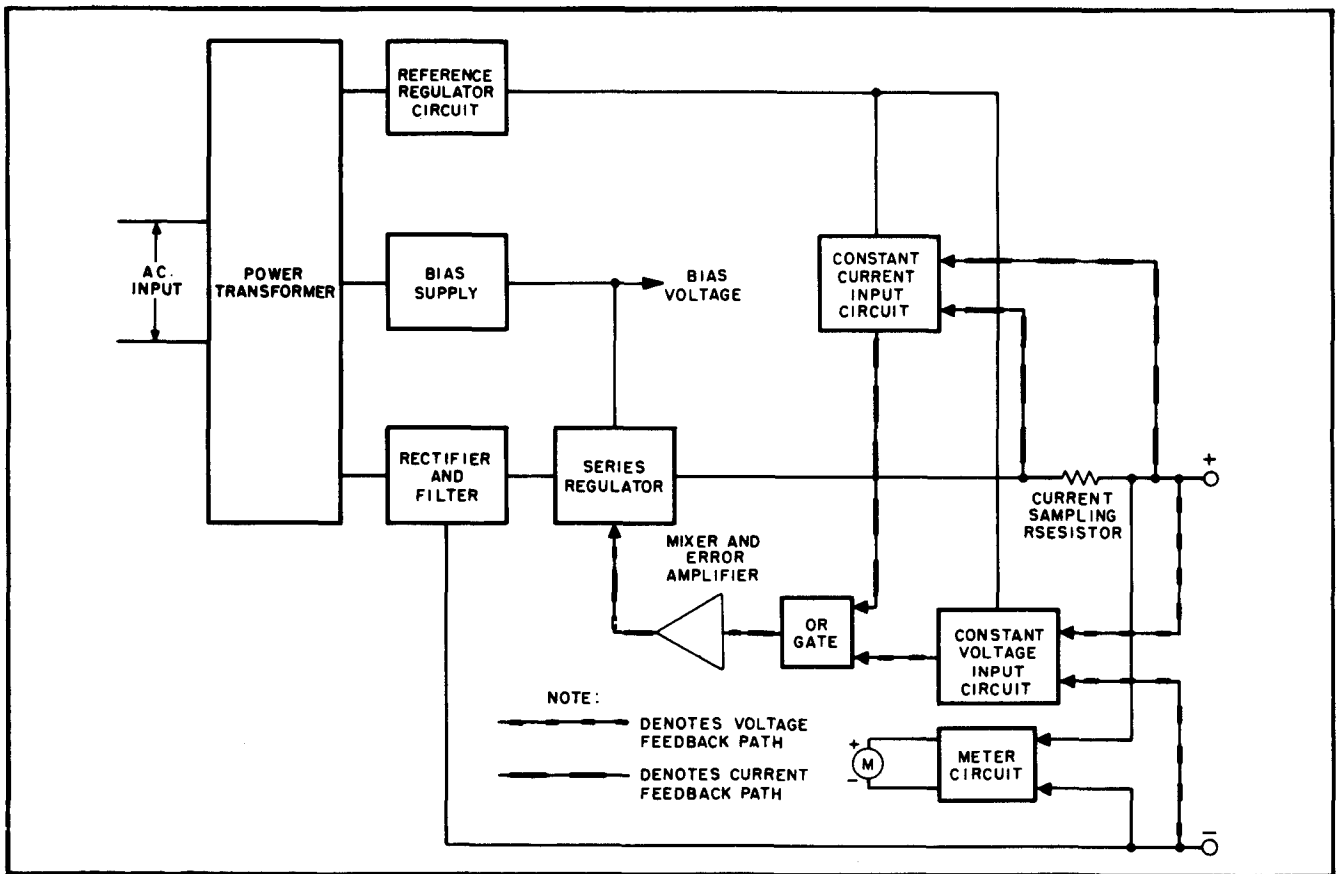

Figure 4-1. Overall Block Diagram

4-1 OVERALL BLOCK DIAGRAM DISCUSSION

4-2 The power supply, as shown on the overall block diagram on Figure 4-1, consists of a power transformer, a rectifier and filter, a series regulator, the mixer and error amplifiers, an "OR" gate, a constant voltage input circuit, a constant current input circuit, a reference regulator circuit, a bias supply, and a metering circuit.

4-3 The input line voltage passes through the power transformer to the rectifier and filter. The rectifier-filter converts the AC input to raw DC which is fed to the positive terminal via the regulator and current sampling resistor network. The regulator, part of the feedback loop, is made to alter its conduction to maintain a constant output voltage or current. The voltage developed

across the current sampling resistor network is the input to the constant current input circuit. The constant voltage input circuit obtains its input by sampling the output voltage of the supply.

4-4 Any changes in output voltage/current are detected in the constant voltage/constant current input circuit, amplified by the mixer and error amplifiers, and applied to the series regulator in the correct phase and amplitude to counteract the change in output voltage/output current. The reference circuit provides stable reference voltages which are used by the constant voltage/current input circuits for comparison purposes. The bias supply furnishes voltages which are used throughout the instrument for biasing purposes. The meter circuit provides an indication of output voltage or current for both operating modes.

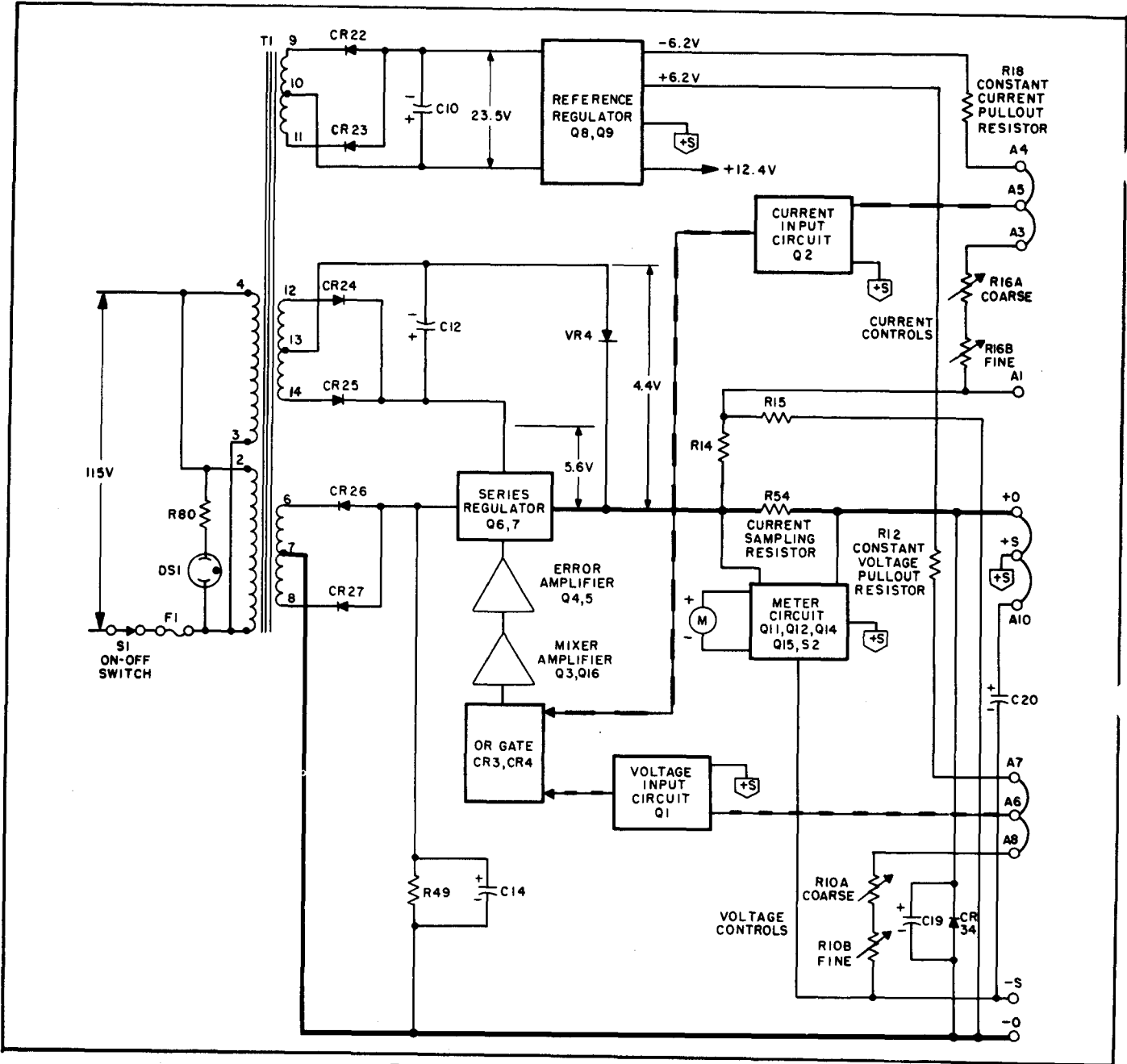

Figure 4-2. Simplified Schematic

4-5 SIMPLIFIED SCHEMATIC (See Figure 3-1 for controls and indicators.)

4-6 A simplified schematic of the power supply is shown in Figure 4-2. It shows the operating controls; the ON-off switch, the voltage and current programming controls R10 and R16. Figure 4-2 also shows the internal sources of bias and reference voltages and their nominal magnitudes with an input of 115 VAC.

4-7 Diode CR34, connected across the output

terminals of the power supply, is a protective device which prevents internal damage that might occur if a reverse voltage were applied across the output terminals. Output capacitor, C20, is also connected across the output terminals when the normal strapping pattern shown on Figure 4-2 is employed. Note that this capacitor can be removed if an increase in the programming speed is desired. Under these conditions, capacitor C19 serves to insure loop stability.

4-8 DETAILED CIRCUIT ANALYSIS [Refer to overall schematic diagram (FO-1) at rear of manual.]

4-9 FEEDBACK LOOP (See Figure 3-1 for controls and indicators.)

4-10 The feedback loop functions continuously to keep the output voltage constant, during constant voltage operation, and the output current constant, during constant current operation. For purposes of this discussion, assume that the unit is in constant voltage operation and that the programming resistors R10 A and B have been adjusted so that the supply is yielding the desired output voltage. Further assume that the output voltage instantaneously rises (goes positive) due to a variation in the external load circuit.

4-11 Note that the change maybe in the form of a slow rise in the output voltage or a positive going AC signal. An AC signal is coupled to summing point A6 through capacitor C1 and a DC voltage is coupled to A6 through R10.

4-12 The rise in output voltage causes the voltage at A6 and thus the base of Q1A to decrease (go negative). Q1A now decreases its conduction and its collector voltage rises. The positive going error voltage is amplified and inverted by Q3 and fed to the bases of series transistors Q6 and Q7 via emitter followers Q5 and Q4. The negative going input causes Q6 and Q7 to decrease their conduction so that they drop more of the line voltage, and reduce the output voltage to its original level.

4-13 If the external load resistance is decreased to a certain crossover point, the output current increases until transistor Q2A begins to conduct. During this time, the output voltage has also decreased to a level so that the base of Q1A is at a high positive potential. With Q1A in full conduction, its collector voltage decreases by the amount necessary to back bias OR gate diode CR3 and the supply is now in the constant current mode of operation. The crossover point at which constant current operation commences is determined by the setting of CURRENT control R16. The operation of the feedback loop during the constant current operating mode is similar to that occurring during constant voltage operation except that the input to the differential amplifier comparison circuit is obtained from the current sampling resistor network.

4-14 SERIES REGULATOR

4-15 The series regulator consists of transistor stages Q6 and Q7 (see schematic at rear of manual). Transistor Q6 is the series element, or pass transistor, which controls the output. Transistor Q7, together with shunt resistors R81, R82, and R83, are connected in a manner which minimizes the power

dissipated in series transistor Q6. The bias voltage for Q7 is developed across zener diode VR5, The conduction of Q7 will decrease as the collector-to-emitter voltage of Q6 approaches the voltage developed across the biasing diodes, At low output voltages Q7 is completely cutoff and all of the load current flows through the shunt resistors. The voltage that is dropped across Q7 and the shunt resistors reduces the voltage dropped across Q6, thus diminishing its power dissipation. The reliability of the regulator is further increased by mounting the shunt resistors outside the rear of the cabinet so that the internal components are operated under lower temperature conditions. Diode CR11, connected across Q6, protects it from reverse voltages that could develop across it during parallel or auto-parallel operation if one supply is turned on before the other. Diodes CR18 and CR19 perform a similar function for Q7.

4-16 CONSTANT VOLTAGE INPUT CIRCUIT (See Figure 3-1 for controls and indicators.)

4-17 The circuit consists of programming resistor R10A and B, and a differential amplifier stage (Q1 and associated components). Transistor Q1 consists of two transistors housed in a single package. The transistors have matched characteristics minimizing differential voltages due to mismatched stages. Moreover, drift due to thermal differentials is minimized, since both transistors operate at essentially the same temperature.

4-18 The constant voltage input circuit continuously compares a fixed reference voltage with a portion of the output voltage and, if a difference exists, produces an error voltage whose amplitude and phase is proportional to the difference. The error output is fed back to the series regulator, through an OR gate and the mixer/error amplifiers. The error voltage changes the conduction of the series regulator which, in turn, alters the output voltage so that the difference between the two input voltages applied to the differential amplifier is reduced to zero. The above action maintains the output voltage constant.

4-19 Stage Q1B of the differential amplifier is connected to a common (+S) potential through impedance equalizing resistor R5. Resistors R6 and R8 are used to zero bias the input stage, offsetting minor base-to-emitter voltage differences in Q1. The base of Q1A is connected to a summing point at the junction of the programming resistor and the current pullout resistor, R12. Instantaneous changes in output voltage result in an increase or decrease in the summing point potential. Q1A is then made to conduct more or less, in accordance with the summing point voltage change. The re-

sultant output error voltage is fed back to the series regulator via OR-gate diode CR3 and the remaining components of the feedback loop. Resistor R1, in series with the base of Q1A, limits the current through the programming resistor during rapid voltage turn-down. Diodes CR1 and CR2 form a limiting network which prevent excessive voltage excursions from over driving stage Q1A. Capacitors C and C shunting the programming resistors, increase the high frequency gain of the input amplifier. Resistor R13, shunting pullout resistor R12, serves as a trimming adjustment for the programming current.

4-20 CONSTANT CURRENT INPUT CIRCUIT
(See Figure 3-1 for controls and indicators.)

4-21 This circuit is similar in appearance and operation to the constant voltage input circuit. It consists basically of the current programming resistors R16A and B, and a differential amplifier stage (Q2 and associated components). Like transistor Q1 in the voltage input circuit, Q2 consists of two transistors, having matched characteristics, that are housed in a single package.

4-22 **The constant current input circuit continuously compares a fixed reference voltage with the voltage drop across the current sampling resistor R54. If a difference exists, the differential amplifier produces an error voltage which is proportional to this difference. The remaining components in the feedback loop (amplifiers and series regulator) function to maintain the drop across the current sampling resistors, and consequently the output current, at a constant value.**

4-23 Stage Q2B is connected to a common (+S) potential through impedance equalizing resistor R26. Resistors R25 and R28 are used to zero bias the input stage, offsetting minor base-to-emitter voltage differences in Q2. Instantaneous changes in output current on the positive line are felt at the current summing point and, hence, the base of Q2A. Stage Q2A varies its conduction in accordance with the polarity of the change at the summing point. The change in Q2A's conduction also varies the conduction of Q2B due to the coupling effects of the common emitter resistor, R22. The error voltage is taken from the collector of Q2B and fed back to the series regulator through OR-gate diode CR4 and the remaining components of the feedback loop. The error voltage then varies the conduction of the regulator so that the output current is maintained at the proper level.

4-24 Resistor R20, in conjunction with R21 and C3 helps stabilize the feedback loop. Diode CR5 limits voltage excursions on the base of Q2A. Resistor R19, shunting the pullout resistor, serves as a trimming adjustment for the programming current flowing through R16.

4-25 VOLTAGE CLAMP CIRCUIT

4-26 During constant current operation the constant voltage programming resistors are a shunt load across the output terminals of the power supply. If the output voltage changed, the current through these resistors would tend to change resulting in an output current change. The clamp circuit is a return path for the voltage programming current, the current that normally flows through the programming resistors. The circuit maintains the current into the constant voltage summing point (A6) constant, thus eliminating the error due to shunting effects of the constant voltage programming resistors.

4-27 The voltage divider, R51, R52, and VR3, back biases C and Q1 during constant voltage operation. When the power supply goes into constant current operation, CR30 becomes forward biased by the collector voltage of Q1A. This results in conduction of Q1 and the clamping of the summing point at a potential only slightly more negative than the normal constant voltage potential. Clamping this voltage at approximately the same potential that exists in constant voltage operation, results in a constant voltage across, and consequently a constant current through the pullout resistor (R12).

4-28 MIXER AND ERROR AMPLIFIERS

4-29 The mixer and error amplifiers amplify the error signal from the constant voltage or constant current input circuit to a level sufficient to drive the series regulator transistors. The emitter bias potential for mixer amplifier Q3 is established by the emitter follower. Transistor Q3 receives the error voltage input from either the constant voltage or constant current circuit via the OR-gate diode (CR3 or CR4) that is conducting at that time. Diode CR3 is forward biased, and CR4 reversed biased, during constant voltage operation. The reverse is true during constant current operation.

4-30 The RC network, composed of C5 and R30, is an equalizing network which provides for high frequency roll off in the loop gain response in order to stabilize the feedback loop. Emitter follower transistors Q4 and Q5 are the error amplifiers serving as the driver and predriver elements, respectively, for the series regulator. Transistor Q4, together

with diode CR17, provides a low resistance discharge path for the output capacitance of the power supply during rapid down programming.

4-31 REFERENCE CIRCUIT

4-32 The reference circuit is a feedback power supply similar to the main supply. It provides stable reference voltages which are used throughout the unit. The reference voltages are all derived from smoothed DC obtained from the full wave rectifier (CR22 and CR23) and filter capacitor C10. The +6.2 and -6.2 voltages, which are used in the constant voltage and current input circuits for comparison purposes, are developed across temperature compensated Zener diodes VR1 and VR2. Resistor R43 limits the current through the Zener diodes to establish an optimum bias level.

4-33 The regulating circuit consists of series regulating transistor Q9 and error amplifier Q8. Output voltage changes are detected by Q8 whose base is connected to the junction of a voltage divider (R41, R42) connected directly across the supply. Any error signals are amplified and inverted by Q8 and applied to the base of series transistor Q9. The series element then alters its conduction in the direction and by the amount necessary to maintain the voltage across VR1 and VR2 constant. Resistor R46, the emitter resistor for Q8, is connected in a manner which minimizes changes in the reference voltage caused by variations in the input line. Output capacitor C9 stabilizes the regulator loop.

4-34 METER CIRCUIT (See Figure 3-1 for controls and indicators).

4-35 The meter circuit provides continuous indications of output voltage or current on a single multiple range meter. The meter can be used either as a voltmeter or an ammeter depending upon the position of the METER switch S2 on the front panel of the supply. This switch also selects one of two meter ranges on each scale. The meter circuit consists basically of a selection circuit (switch S2 and associated voltage dividers), stable differential amplifier stages (Q1 Q12, and Q14), and the meter movement.

4-36 The selection circuit determines which voltage divider is connected to the differential amplifier input. When the METER section of S2 is in one of the voltage positions the voltage across divider R59, R60, and R61 (connected across the output of the supply) is the input to the differential amplifier.

4-37 When S2 is in one of the current positions the voltage across divider R56, R57, and R58 is the input to the differential amplifier. Note that

this divider is connected across the sampling resistor network. The amplified output of the differential amplifier is used to deflect the meter.

4-38 The differential amplifier is a stable device having a fixed gain of ten. Stage Q1 of the amplifier receives a negative voltage from the applicable voltage divider when S is in one of the voltage positions while stage Q11A is connected to the +S (common) terminal. With S2 in a current position, stage Q11A receives a positive voltage from the applicable voltage divider while stage Q1 is connected to the +S terminal. The differential output of the amplifier is taken from the collectors of Q12 and Q14. Transistor Q15 is a constant current source which sets up the proper bias current for the amplifier. Potentiometer R63 permits zeroing of the meter.

4-39 The meter amplifier contains an inherent current limiting feature which protects the meter movement against overloads. For example, if METER switch S is placed in the low current range when the power supply is actually delivering a higher ampere output, the differential amplifiers are quickly driven into saturation limiting the current through the meter to a safe value.

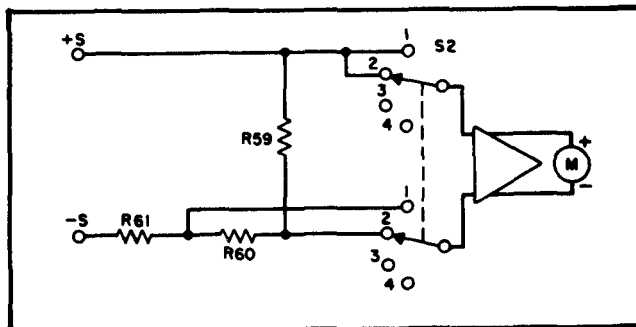

Figure 4-3. Voltmeter Connections, Simplified Schematic

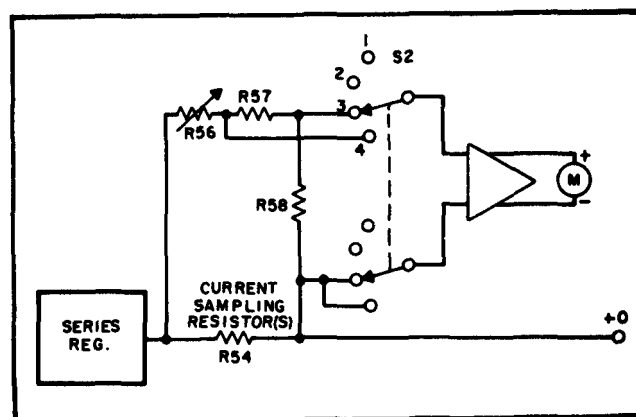

Figure 4-4. Ammeter Connections, Simplified Schematic

4-40 Figures 4-3 and 4-4 show the meter connections when the METER section of S2 is in the higher voltage and current range positions, respectively. For the sake of simplicity, some of the actual circuit components are not shown on these draw. With the METER switch in the higher voltage range, position 2, the voltage drop across R59 is the input to the meter amplifier and the meter indicates the output voltage across the +S and -S terminals. For low output voltages, S2 can be switched to the low voltage position (1) resulting in the application of a larger percentage of the

output voltage (drop across R59 and R60) to the meter amplifier.

4-41 As illustrated in Figure 4-4 with the METER switch in the high current position (3) the voltage drop across R58 is applied to the meter amplifier and the meter indicates the output current which flows through the sampling resistor network. For low values of output current, the METER switch can be set to position 4 and the voltage drop across R57 and R58 is applied to the meter amplifier.

SECTION V
MAINTENANCE

5-1 INTRODUCTION

———— CAUTION ————

Do not directly short out any of the large capacitors as it places too much stress on them. Discharge capacitors through a load resistor.

5-2 Upon receipt of the power supply, the performance check (Paragraph 5-10) should be made. This check is suitable for incoming inspection. If a fault is detected in the power supply while making the performance check or during normal operation, proceed to the troubleshooting procedures (Paragraph 5-41). After trouble shoot and repair (Paragraph 5-46), perform any necessary adjustments and calibrations (Paragraph 5-48). Before returning the power supply to normal operation, repeat the performance check to ensure that the fault has been properly corrected and that no other faults exist. Before doing any maintenance checks, turn on power supply, allow a half-hour warm-up, and read the general information regarding measurement techniques (Paragraph 5-3).

5-3 GENERAL MEASUREMENT TECHNIQUES

WARNING

Do not touch heat sinks or power transistors mounted on heat sinks as they are very hot after instrument has been on and operating.

5-4 The measuring device must be connected across the sensing leads of the supply or as close to the output terminals as possible when measuring the output impedance, transient response, regulation, or ripple of the power supply in order to achieve valid measurements. A measurement made across the load includes the impedance of the leads to the load and such lead lengths can easily have an impedance several orders of magnitude greater than the supply impedance, thus invalidating the measurement.

5-5 The monitoring device should be connected to the +S and -S terminals (see Figure 3-2) or as

shown in in Figure 5-1. The performance characteristics should never be measured on the the front terminals terminals if the load is connected across the rear terminals. Note that when that when measurements are made at the the front terminals, the monitoring leads are connected at A, not B, as shown in Figure 5-1. Failure to connect the measuring device at A will result in will result in a measurement that includes the resistance of the leads between the output terminals and the point of connection.

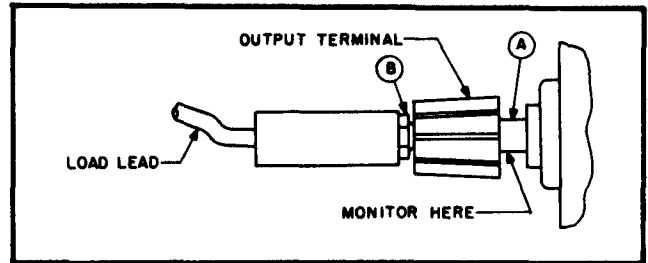

Figure 5-1. Front Panel Terminal Connections

5-6 For output current measurements, the current sampling resistor should be a four-terminal resistor. The four terminals are connected as shown in Figure 5-2. In addition, the resistor should be of the low noise, low temperature coefficient (less than 30ppm/°C) type and should be used at no more than 5% of its rated power so that its temperature rise will be minimized.

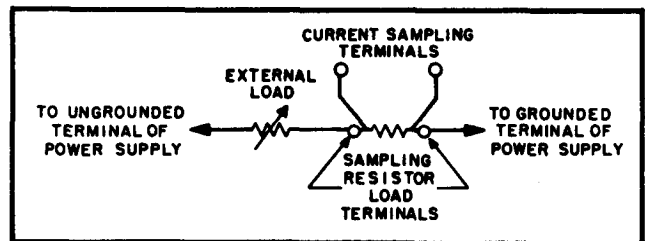

Figure 5-2. Output Current Mea Technique

5-7 When using an oscilloscope, ground one terminal of the power supply and then ground the case of the oscilloscope to this same point. Make certain that the case is not also grounded by some other means (Power line). Connect both oscilloscope input leads to the power supply ground terminal and check that the oscilloscope is not exhibiting a ripple or transient due to ground loops, pick-up, or other means.

5-8 **TEST EQUIPMENT REQUIRED**

5-9 Table 5-1 lists the test equipment required to perform the various procedures described in this Section.

CAUTION

Care must be exercised when using an electronic null detector in which one input terminal is grounded to avoid ground loops and circulating currents.

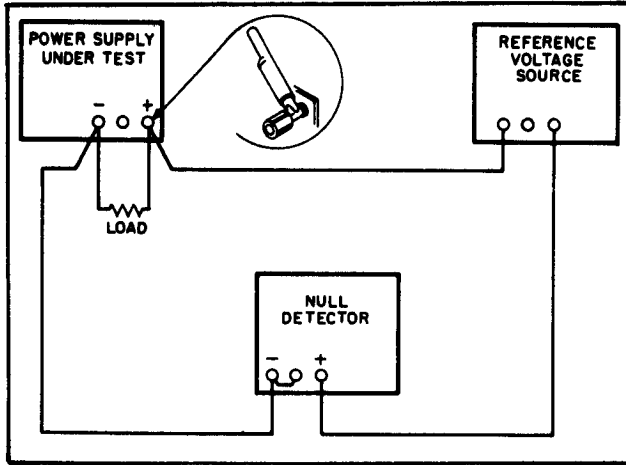

Figure 5-3. Differential Voltmeter Substitute, Test Setup

5-10 **PERFORMANCE TEST**

5-11 The following test can be used as an incoming inspection check and appropriate portions of the test can be repeated either to check the operation of the instrument after repairs or for periodic maintenance tests. The tests are performed using a 115Vac 60 single phase input power source. If the correct result is not obtained for a particular check, do not adjust any controls; proceed to troubleshooting (Paragraph 5-41).

5-12 **CONSTANT VOLTAGE (CV) TESTS (See Figure 3-1 for controls and indicators.)**

5-13 **Rated Output and Meter Accuracy.**

5-14 Voltage. Proceed as follows:

a. Connect load resistor across rear output terminals of supply. Resistor value to be as follow

Model	6253A	6255A	6281A	6284A	6289A	6294A
Resistance	6Ω	26Ω	1.5Ω	6Ω	26Ω	6Ω

b. Connect differential voltmeter across +S and -S terminals of supply observing correct polarity.

- c. Set METER switch to highest voltage range and turn on supply.
- d. Adjust VOLTAGE control(s) until front panel meter indicates exactly the maximum rated output voltage.
- e. Differential voltmeter should indicate maximum rated output voltage within ±2%.

5-15 Current. Proceed as follows:

- a. Connect test setup as shown in Figure 5-4 leaving switch S1 open.
- b. Turn CURRENT controls fully clockwise.
- c. Set METER switch to highest current range and turn on supply.
- d. Adjust VOLTAGE control(s) until front panel meter indicates exactly the maximum rated output current.
- e. Differential voltmeter should read 1.0 ± 0. Vdc.

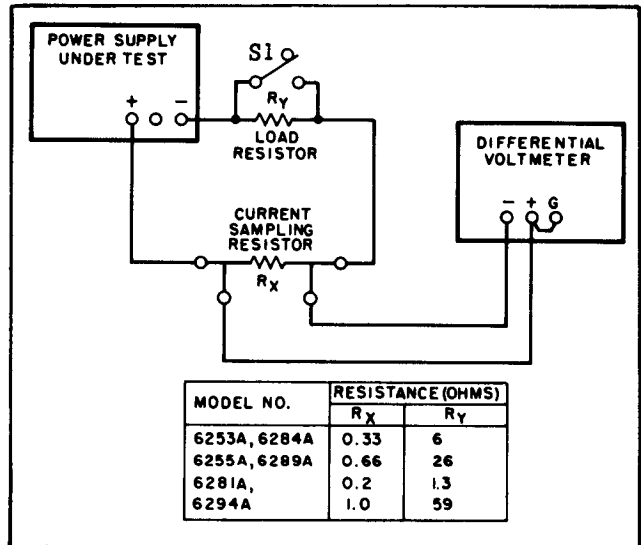

Figure 5-4. Output Current Test Setup

5-16. Load Regulation. To check constant voltage load regulation, proceed as follows:

- a. Connect test setup as shown in Figure 5-5.
- b. Turn CURRENT controls fully clockwise.
- c. Set METER switch to highest current range and turn on supply.
- d. Adjust VOLTAGE control(s) until front panel meter indicates exactly the maximum rated output voltage.
- e. Read and record voltage indicated on differential voltmeter.
- f. Disconnect load resistors.
- g. Reading on differential voltmeter should not vary from reading recorded in step e by more than the follow

Table 5-1. Test Equipment Required

TYPE	REQUIRED CHARACTERISTICS	USE	RECOMMENDED MODEL
Different Voltmeter	Sensitivity: 1mV full scale (min. Input impedance: 10 megohms (min.)).	Measure DC voltages; calibration procedures	Ⓢ 3420 (See Note)
Variable Voltage Transformer	Range: 90-130 volts. Equipped with voltmeter accurate within 1 volt.	Vary AC input	---
AC Voltmeter	Accuracy: 2%. Sensitivity: 1mV full scale deflection (min.	Measure AC voltages and ripple	Ⓢ 403B
Oscilloscope	Sensitivity: 100μV/cm. Differential input.	Display transient response waveforms	Ⓢ 140A plus 1400A plug-in. 1402A plug-in for spike measurement only,
Oscillator	Range: 5 Hz to 600 kHz. Accuracy: 2%. Output: 1 rms.	Impedance checks	Ⓢ : 200 CD
DC Voltmeter	Accuracy: 1%. Input resistance: 20, 000 ohms/volt (min.	Measure DC voltages	Ⓢ 412A
Repetitive Load Switch	Rate: 60 - 400 Hz, 2μsec rise and fall time.	Measure transient response	See Figure 5-8.
Resistive Loads	Values: See Paragraph 5-14 and Figure 5-4. ±5%, 75 watts.	Power supply load resistors	---
Current Sampling Resistor	6253A, 6284A: 0.Ω 6255A, 6289A: 0.Ω 6281A: 0. Ω 6294A: 1.Ω	Measure current; calibrate meter; constant current (CC) ripple and noise	See Parts List R54
Resistor	1 KΩ ±1%, 2 watt non-inductive.	Measure impedance	---
Resistor	100 ohms, ±5%, 10 watt.	Measure impedance	---
Resistor	Value: See Paragraph 5-59. ±0.1%, 1/2 watt.	Calibrate programming current	---
Resistor	Value: See Paragraph 5-62. ±0.1% 1/2 watt.	Calibrate programming current	---
Capacitor	500μf, 50 wVdc.	Measure impedance	---
Decade Resistance Box	Range: 0-50 Accuracy: 0.1% plus 1 ohm. Make-before-break contacts.	Measure programming coefficients	---

NOTE

A satisfactory substitute for a differential voltmeter is to arrange a reference voltage source and null detector as shown in Figure 5-3. The reference voltage source is adjusted so that the voltage difference between the supply being measured and the reference voltage will have the required resolution for the measurement being made. The voltage difference will be a function of the null detector that is used. Examples of satisfactory null detectors are: 419A null detector, a dc coupled oscilloscope utilizing differential input, or a 50mV meter movement with a 100 division scale. For the latter, a 2mV change in voltage will result in a meter deflection of four divisions.

Model No.	6253A, 6284A	6255A, 6269A
Variation (mVdc)	±6	±6
Model No.	6281A	6294A
Variation (mVdc)	±5	±8

5-17 Line Regulation: To check the line regulation, proceed as follows:

- Connect variable auto transformer between input power source and power supply power input.
- Turn CURRENT controls fully clockwise.
- Connect test setup shown in Figure 5-5.
- Adjust variable auto transformer for 105Vac input.
- Set METER switch to highest voltage range and turn on supply.
- Adjust VOLTAGE control(s) until front panel meter indicates exactly the maximum rated output voltage.
- Read and record voltage indicated on differential voltmeter.
- Adjust variable auto transformer for 125Vac input.

i. Reading on differential voltmeter should not vary from reading recorded in step g by more than the following:

Model No.	6253A, 6284A	6255A, 6289A
Variation (mVdc)	±4	±6
Model No.	6281A	6294A
Variation (mVdc)	±2.75	±8

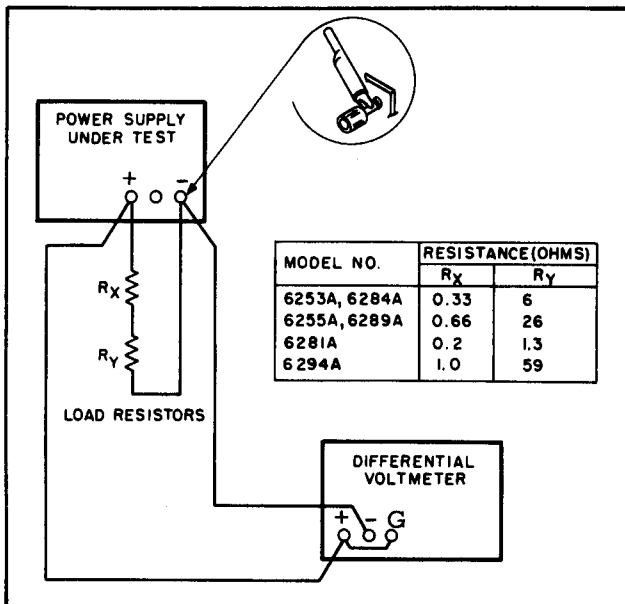

Figure 5-5. Load Regulation, Constant Voltage Test Setup

5-18 Ripple and Noise. Ripple and noise measurement can be made at any input AC line voltage combined with any DC output voltage and load current within rating.

5-19 The amount of ripple and noise that is present on the power supply output is measured either in terms of the RMS or (preferably) peak-to-peak value. The peak-to-peak measurement is particularly important for applications where noise spikes could be detrimental to a sensitive load, such as logic circuitry. The RMS measurement is not an ideal representation of the noise, since fairly high output noise spikes of short duration could be present in the ripple and not appreciably increase the RMS value.

5-20 The technique used to measure high frequency noise or "spikes" on the output of a power supply is more critical than the low frequency ripple and noise measurement technique; therefore the former is discussed separately in Paragraph 5-28.

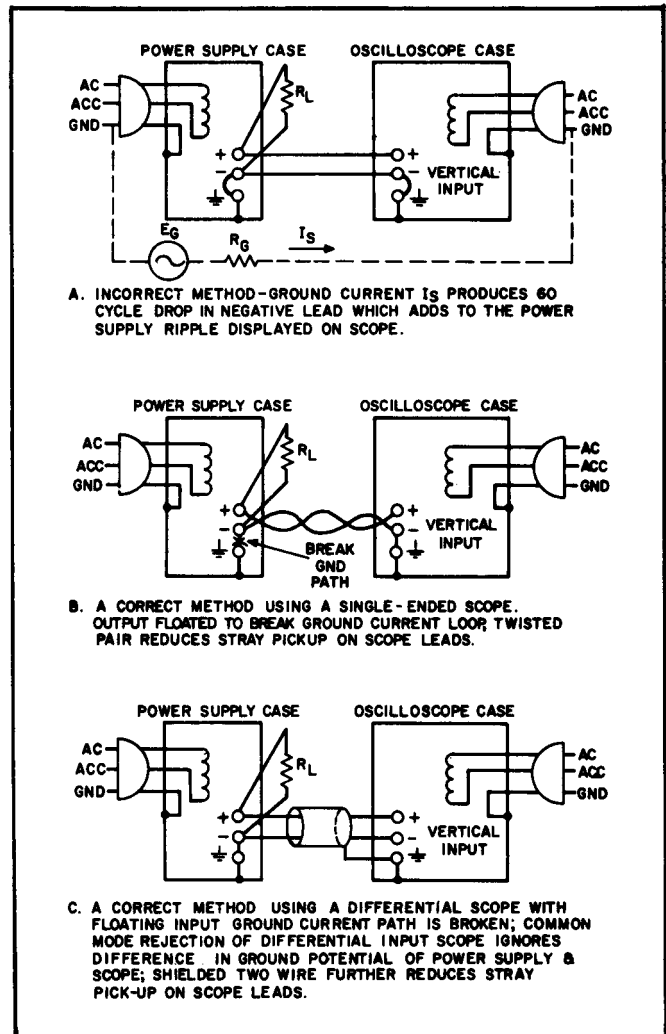

Figure 5-6. CV (Constant Voltage) Ripple and Noise Test Setup

5-21 Ripple and Noise Measurements. Figure 5-6A shows an incorrect method of measuring p-p ripple. Note that a continuous ground loop exists from the third wire of the input power cord of the supply to the third wire of the input power cord of the oscilloscope via the grounded power supply case, the wire between the negative output terminal of the power supply and the vertical input of the scope, and the grounded scope case. Any ground current circulating in this loop as a result of the difference in potential E_G between the two ground points causes an IR drop which is in series with the scope input. This IR drop, normally having a 60Hz line frequency fundamental, plus any pickup on the unshielded leads interconnecting the power supply and scope, appears on the face of the CRT. The magnitude of this resulting noise signal can easily be much greater than the true ripple developed between the plus and minus output terminals of the power supply, and can completely invalidate the measurement.

5-22 The same ground current and pickup problems can exist if an RMS voltmeter is substituted in place of the oscilloscope in Figure 5-6. However, the oscilloscope display, unlike the true RMS meter reading, tells the observer immediately whether the fundamental period of the signal displayed is 8.3 milliseconds (1/120 Hz) or 16.7 milliseconds (1/60 Hz). Since the fundamental ripple frequency present on the output of an AC supply is 120 Hz (due to full-wave rectification), an oscilloscope display showing a 120 Hz fundamental component is indicative of a "clean" measurement setup, while the presence of a 60 Hz fundamental usually means that an improved setup will result in a more accurate (and lower) value of measured ripple.

5-23 Figure 5-6B shows a correct method of measuring the output ripple of a constant voltage power supply using a single-ended scope. The ground loop path is broken by floating the supply output. Note that to ensure that no potential difference exists between the supply and the oscilloscope, it is recommended that whenever possible they both be plugged into the same AC power buss. If the same buss cannot be used, both AC grounds must be at earth ground potential.

5-24 Either a twisted pair or (preferably) a shielded two-wire cable should be used to connect the output terminals of the power supply to the vertical input terminals of the scope. When using a twisted pair, care must be taken that one of the two wires is connected to the grounded input terminal of the oscilloscope. When using shielded two-wire, it is essential for the shield to be connected to ground at one end only so that no ground current

will flow through this shield, thus inducing a noise signal in the shielded leads.

5-25 To verify that the oscilloscope is not displaying ripple that is induced in the leads or picked up from the grounds, the (+) scope lead should be shorted to the (-) scope lead at the power supply terminals. The ripple value obtained when the leads are shorted should be subtracted from the actual ripple measurement.

5-26 In most cases, the single-ended scope method of Figure 5-6B will be adequate to eliminate non-real components of ripple and noise so that a satisfactory measurement may be obtained. However, in more stubborn cases it may be necessary to use a differential scope with floating input as shown in Figure 5-6C. If desired, two single conductor shielded cables may be substituted in place of the shielded two-wire cable with equal success. Because of its common mode rejection, a differential oscilloscope displays only the difference in signal between its two vertical input terminals, thus ignoring the effects of any common mode signal introduced because of the difference in the AC potential between the power supply case and scope case. Before using a differential input scope in this manner, however, it is imperative that the common mode rejection capability of the scope be verified by shorting together its two input leads at the power supply and observing the trace on the CRT. If this trace is a straight line, the scope is properly ignoring any common mode signal present. If this trace is not a straight line, then the scope is not rejecting the ground signal and must be realigned in accordance with the manufacturer's instructions until proper common mode rejection is attained.

5-27 To check the ripple and noise output, proceed as follows:

- a. Connect the oscilloscope or RMS voltmeter as shown in Figures 5-6B or 5-6C.
- b. Turn the CURRENT control fully clockwise and adjust VOLTAGE control until front panel meter indicates maximum rated output voltage.
- c. The observed ripple and noise should be less than 200 μ V RMS and 1mV p-p.

5-28 Noise Spike Measurement. When a high frequency spike measurement is being made, an instrument of sufficient bandwidth must be used; an oscilloscope with a bandwidth of 20 MHz or more is adequate. Measuring noise with an instrument that has insufficient bandwidth may conceal high frequency spikes detrimental to the load.

5-29 The test setups illustrated in Figures 5-6A

and 5-6B are generally not acceptable for acceptable for measuring spikes; a differential oscilloscope is needed. Furthermore, the measurement concept of Figure 5-6C must be modified if accurate spike measurement is to be achieved:

1. As shown in Figure 5-7, two coax cables, must be substituted for the shielded two-wire cable.
2. Impedance matching resistors must be included to eliminate standing waves and cable ringing, and the capacitors must be connected to block the DC current path.

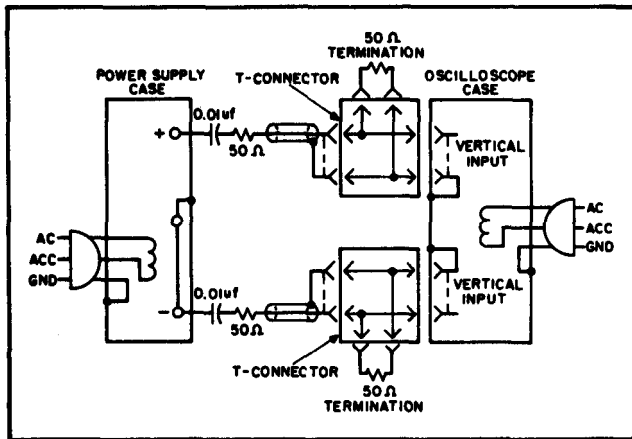

Figure 5-7. CV Noise Spike Test Setup

3. The length of the test leads outside the coax is critical and must be kept as short as possible; the blocking capacitor and the impedance matching resistor should be connected directly from the inner conductor of the cable to the power supply terminals.

4. Notice that the shields of the power supply end of the two coax cables are not connected to the power supply ground, since such a connection would give rise to a ground current path through the coax shield, resulting in an erroneous measurement.

5. The measured noise spike values must be doubled, since the impedance matching resistors constitute a 2-to-1 attenuator.

6. The noise spikes observed on the oscilloscope should be less than 0. p-p.

5-30 The circuit of Figure 5-7 can also be used for the normal measurement of low frequency ripple and noise; simply remove the four terminating resistors and the blocking capacitors and substitute a higher gain vertical plug-in in place of the wide-band plug-in required for spike measurements. Notice that with these changes, Figure 5-7 becomes a two-cable version of Figure 5-6C.

5-31 Transient Recovery Time. To check the transient recovery time proceed as follows:

- a. Connect test setup shown in Figure 5-8.
- b. Turn CURRENT controls fully clockwise.
- c. Set METER switch to highest current range and turn on supply.
- d. Adjust VOLTAGE control(s) until front panel meter indicates exactly the maximum rated output voltage.
- e. Close line switch on repetitive load switch setup.
- f. Adjust 25 potentiometer until a stable display is obtained on oscilloscope. Waveform should be within the tolerances shown in Figure 5-9 (output should return to w within 15mV of original value in less than 50 microseconds).

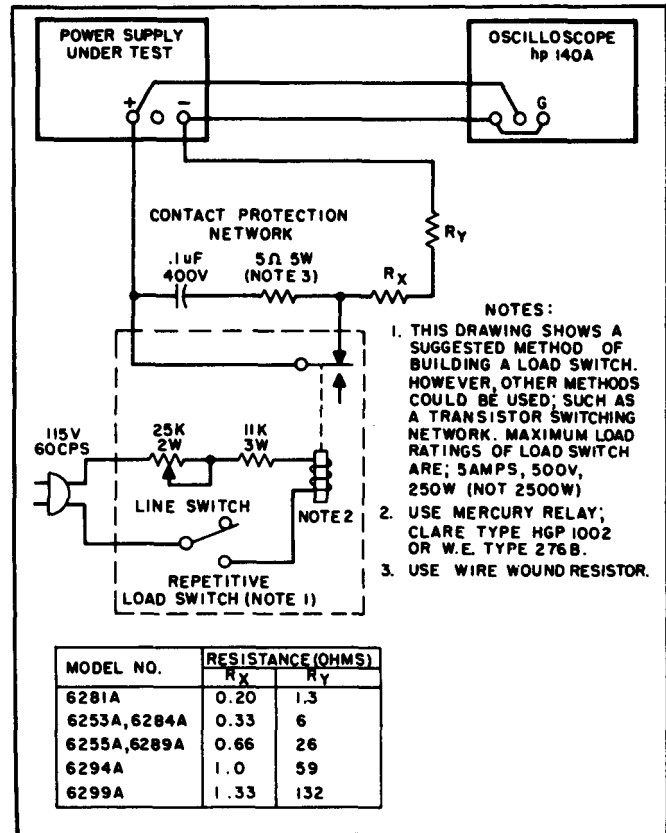

Figure 5-8. Transient Response, Test Setup

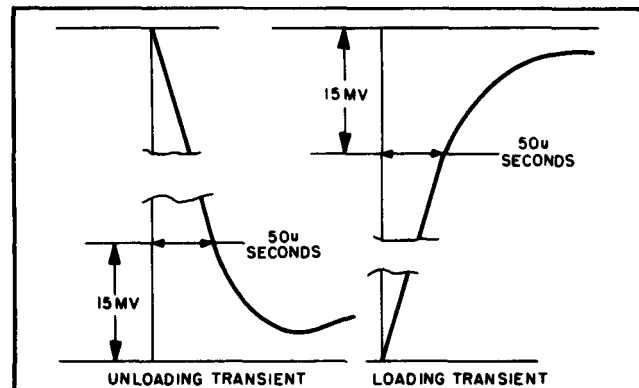

Figure 5-9. Transient Response, Waveforms

5-32 Programming Speed. This measurement is made by monitoring the output voltage with an oscilloscope while rapidly changing the remote programming resistance. For up-programming, the remote resistance is varied from zero ohms to the value that will produce maximum output voltage; and for down-programming, the remote resistance is varied from the value that will produce maximum output voltage to zero ohms. To check the up-programming speed, make the connections indicated in Figure 5-10; for down-programming, simply remove R_L .

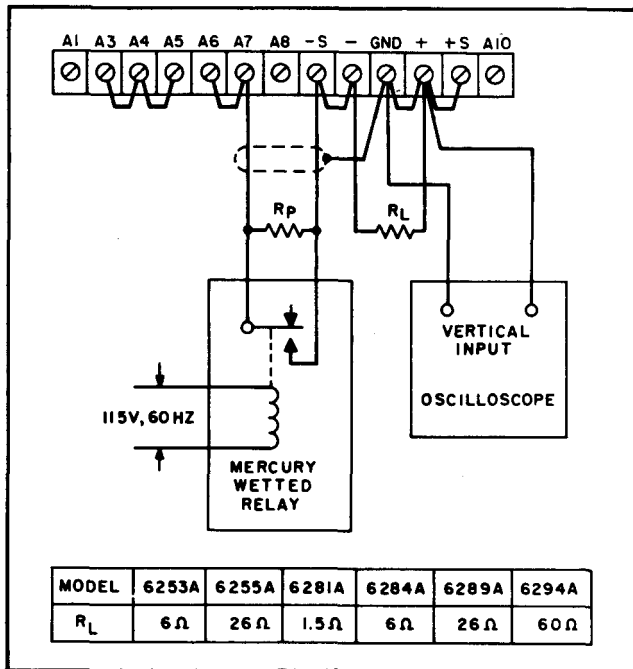

Figure 5-10. CV Programming Speed, Test Setup

The load resistance is included for up-programming and removed for down-programming to present the worst possible conditions for the supply to reach the programmed voltage. Refer to Application Note 90, Power Supply Handbook for further details on remote programming speed. To check the programming speed, proceed as follows:

1. Restrap the rear barrier strip as indicated in Figure 5-10. Note that the jumper between +S and A10 is removed. This disconnects the output capacitor C to increase the programming speed. A minimum amount of output capacitance (C is permanently wired to the output and should not be removed, because the supply could oscillate under certain load conditions. The programming speed increases by a factor of from 10 to 100 when the output capacitor C is removed.

2. Connect the relay, oscilloscope, and programming resistor R_p as illustrated in Figure 5-10. Select the value of the programming resistor that

will produce maximum output voltage of the supply. This value is obtained by multiplying the programming coefficient (200 ohms/volt, 300 ohms/volt for Model 6294A) by the maximum rated output voltage of the supply.

3. A mercury-wetted relay is employed to rapidly switch the programming resistance from zero to maximum at a 60 Hz rate. Other automatic switching devices can be used; however, a hand-operated switch connected across the programming resistor is not adequate, because the resulting one-shot displays are difficult to observe on most oscilloscopes.

4. The time (T) required for the output voltage to change from zero volts to maximum rated output or from maximum rated output to zero should be less than 10 milliseconds.

5-33 Output Impedance. To check the output impedance, proceed as follows:

- a. Connect test setup as shown in Figure 5-11.

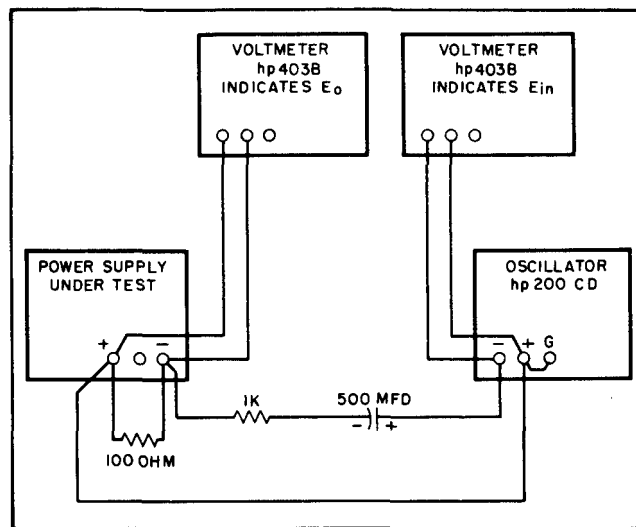

Figure 5-11. Output Impedance, Test Setup

- b. Set METER switch to highest voltage range and turn CURRENT controls fully clockwise, and turn on supply.

- c. Adjust VOLTAGE control(s) until front panel meter reads 20 volts.

- d. Set AMPLITUDE control on Oscillator to 10 volts (E_{in}), and FREQUENCY control to 1 kHz.

- e. Record voltage across output terminals of the power supply (E_o) as indicated on AC voltmeter.

- f. Calculate the output impedance by the following formula: $Z_{out} = (E_o R) / (E_{in} - E_o)$

E_o = rms voltage across power supply output terminals.

$R = 1000.$

$E_{in} = 10$ volts.

- g. The output impedance (Z_{out}) should be less than 0.01 ohm.
- h. Using formula of step f, calculate output impedance at frequencies of 10kHz, 100kHz, and 1MHz. Values should be less than 0.05 ohm, 0.5 ohm, and 5 ohms, respectively.

5-34 CONSTANT CURRENT (CC) TESTS (See Figure 3-1 for controls and indicators.)

5-35 Load Regulation. To check the constant current load regulation, proceed as follows:

- a. Connect test setup as shown in Figure 5-4.
- b. Turn VOLTAGE control(s) fully clockwise.
- c. Set METER switch to highest current range and turn on supply.
- d. Adjust CURRENT control until front panel meter reads exactly the maximum rated output current.
- e. Read and record voltage indicated on differential voltmeter.
- f. Short out load resistor (R_L) by closing switch S1.

g. Reading on differential voltmeter should not vary from reading recorded in step e by more than the following:

Model No.	6253A, 6284A	6255A, 6289A
Variation (mVdc)	±0.183	±0.265
Model No.	6281A	6294A
Variation (mVdc)	±0.5	±0.35

5-36 Line Regulation. To check the line regulation proceed as follows:

- a. Utilize test setup shown in Figure 5-4 leaving switch S1 open throughout test.
- b. Connect variable auto transformer between input power source and power supply power input.
- c. Adjust auto transformer for 105Vac input.
- d. Turn VOLTAGE control(s) fully clockwise.
- e. Set METER switch to highest current range and turn on supply.
- f. Adjust CURRENT controls until front panel meter reads exactly the maximum rated output current.

g. Read and record voltage indicated on differential voltmeter.

h. Adjust variable auto transformer for 125 Vac input.

i. Reading on differential voltmeter should not vary from reading recorded in step g by more than the following:

Model No.	6253A, 6284A	6255A, 6289A
Variation (mVdc)	±0.183	±0.265
Model No.	6281A	6294A
Variation (mVdc)	±0.15	±0.35

5-37 Ripple and Noise. Most of the instructions pertaining to the ground loop and pickup problems

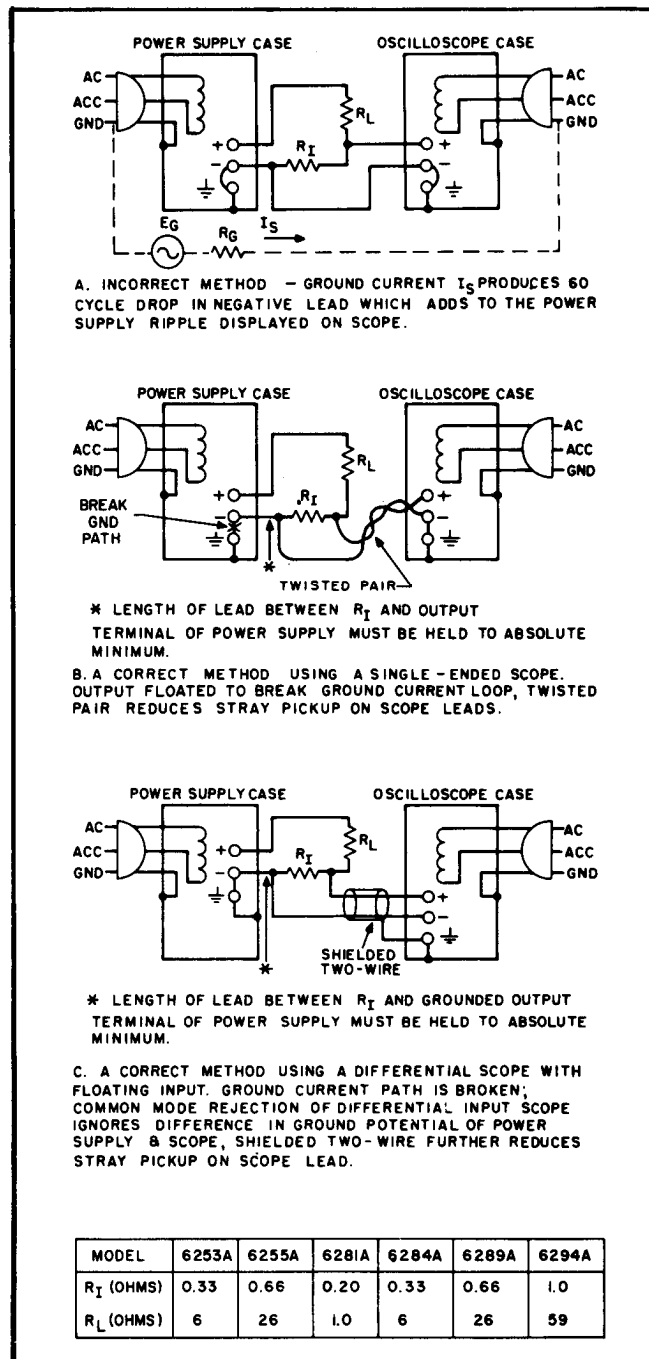

Figure 5-12. CC Ripple and Noise Test Setup

associated with constant voltage ripple and noise measurement also apply to the measurement of constant current ripple and noise. Figure 5-12 illustrates the most important precautions to be observed when measuring the ripple and noise of a constant current supply. The presence of a 120 cycle waveform on the oscilloscope is normally indicative of a correct measurement method. A wave shape having 60 Hz as its fundamental component is typically associated with an incorrect measurement setup.

5-38 Ripple and Noise Measurement. To check the ripple and noise, proceed as follows:

- a. Connect the oscilloscope or RMS voltmeter as shown in Figures 5-12B or 5-12C.
- b. Rotate the VOLTAGE control fully cw.
- c. Set METER switch to highest current range and turn on supply.
- d. Adjust CURRENT control until front panel meter reads exactly the maximum rated output current.
- e. The ripple and noise indication should be less than the following:

Model	6253A,6284A	6255A,6289A	6281A	6294A
mA rms	2	0.5	4	0.5

5-39 TROUBLESHOOTING

5-40 Components within Hewlett-Packard power supplies are conservatively operated to provide maximum reliability. In spite of this, parts within a supply may fail. Usually the instrument must be immediately repaired with a minimum of "down time" and a systematic approach as outlined in succeeding paragraphs can greatly simplify and speed up the repair.

5-41 TROUBLE ANALYSIS

5-42 General. Before attempting to troubleshoot this instrument, ensure that the fault is with the instrument and not with an associated circuit. The performance test (Paragraph 5-10) enables this to be determined without having to remove the instrument from the cabinet.

5-43 Once it is determined that the power supply is at fault, check for obvious troubles such as open fuse, a defective power cable, or an input power failure. Next, remove the top and bottom covers (each held by four retaining screws) and inspect for open connections, charred components, etc. If the trouble source cannot be detected by visual inspection, follow the detailed procedure outlined in succeeding paragraphs. Once the defective component has been located (by means of visual inspection or

trouble analysis) correct it and re-conduct the performance test. If a component is replaced, refer to the repair and replacement and adjustment and calibration paragraphs in this section.

5-44 A good understanding of the principles of operation is a helpful aid in troubleshooting, and it is recommended that the reader review Section IV of the manual before attempting to troubleshoot the unit in detail. Once the principles of operation are understood, logical application of this knowledge used in conjunction with the normal voltage readings shown on the schematic and the additional procedures given in the following paragraphs should suffice to isolate a fault to a component or small group of components. The normal voltages shown on the schematic are positioned adjacent to the applicable test points (identified by encircled numbers on the schematic and printed wiring boards).

5-45 Table 5-2 includes the symptoms and probable causes of many possible troubles. If either high or low output voltage is a symptom, there are two methods of isolating the fault. The first is a simplified procedure that involves only measuring voltages; the second is a more thorough approach requiring that transistor stages be opened or shorted. Both methods are described as follows:

1. First, the reference, bias, and filtered dc voltages as given in Table 5-3 should be checked. Then the voltage levels at critical points (base and collector) in the feedback loop should be measured and compared to the normal voltages given on the overall schematic diagram at the rear of the manual. This method of troubleshooting a feedback loop is not always conclusive; a better method is described in (2).

2. First, measure the reference, bias, and filtered dc voltages as given in Table 5-3. Then, drive each stage in the feedback loop into conduction or cutoff by either shorting or opening the previous stage as indicated in Tables 5-4 or 5-5.

Table 5-2. Common Troubles

Symptom	Probable Cause
Low output or no output voltage	Refer to Table 5-3, then 5-4.
High output voltage	Refer to Table 5-3, then 5-5.
High ripple	<ul style="list-style-type: none"> a. Check operating setup for ground—refer to Paragraph 5-18. b. If output floating, connect 1μf capacitor between output and ground. c. Check for excessive internal ripple; refer to Table 5-3. d. Ensure that supply is not in constant-current operation under loaded conditions. To prevent this condition turn CURRENT control fully clockwise. * e. Check for low voltage across C14, C12, or C10.

Table 5-2. Common Troubles (Continued)

Symptom	Probable Cause
Poor line regulation	<ul style="list-style-type: none"> a. Improper measuring technique; refer to Paragraph 5-3. b. Check reference circuit voltages, Table 5-3. c. Check reference circuit adjustment, Paragraph 5-62.
Poor load regulation (Constant Voltage)	<ul style="list-style-type: none"> a. Improper measuring technique; refer to Paragraph 5-3. b. Check the regulation characteristics of Zener diode VR1 as follows: <ul style="list-style-type: none"> (1) Connect differential voltmeter across VR1 (2) Connect appropriate load resistor (R_y), given in Figure 5-4, across (+) and (-) output terminals (3) Perform steps b through f of Paragraph 5-16 (4) If the differential voltmeter reading varies by more than 0.5mV, replace VR1. c. Ensure that supply is not in constant-current operation under loaded conditions. To prevent this condition turn CURRENT control fully clockwise. *
Poor load regulation (Constant Current)	<ul style="list-style-type: none"> a. Improper measuring technique; refer to Paragraph 5-3. b. Check the regulation characteristics of Zener diode VR2 as follows : <ul style="list-style-type: none"> (1) Connect differential voltmeter across VR2 (2) Connect appropriate load resistor (R_y), given in Figure 5-4, across (+) and (-) output terminals (3) Perform steps b through f of Paragraph 5-35 (4) If the differential voltmeter reading varies by more than 0.5mV, replace VR2. c. C19, C20, and CR34 leaky. d. Check clamp circuit, Q10, CR30, VR3, and CR32. e. Ensure that supply is not crossing over into constant voltage operation. To prevent this condition, load the supply and turn the VOLTAGE control fully clockwise. *
Oscillates	<ul style="list-style-type: none"> a. Check C5 open. Adjustment of R30; refer to Paragraph 5-64. b. Check R21 and C3 in current input circuit.
Poor stability (Constant Voltage)	<ul style="list-style-type: none"> a. Check +6.2Vdc reference voltage (Table 5-3). b. Noisy programming resistor R10. c. CR1, CR2 leaky. d. Check R1, R12, R13, and C2 for noise or drift. e. Stage Q 1 defective.
Poor stability (Constant Current)	<ul style="list-style-type: none"> a. Check -6.2Vdc reference voltage (Table 5-3). b. Noisy programming resistor R16. c. CR5, CR34, C19, C3 leaky. d. Check R18, R19, R20, R21, and R54 for noise or drift. e. Stage Q2 defective.
Poor transient recovery	<ul style="list-style-type: none"> a. Check R30 and C5. Refer to adjustment procedure Paragraph 5-64.

* See Figure 3-1 for controls and indicators.

Table 5-3. Reference, Bias, and filtered DC Troubleshooting

Meter Common	Meter Positive	Normal Vdc	Normal Ripple (P-P)	Probable Cause
31	+S	6.2	0.5mV	VR2
+S	33	6.2	0.5mV	VR1
+S	37	12.4	5 mV	Q8, Q9
34	37	24	1.4V	C10, CR22, CR23, T1
41	23	4.4	20mV	VR4
41	38	28V(6253A) 53V(6255A) 12V(6281A) 28V(6284A) 53V(6289A) 80V(6294A)	3V 1V 2V 3V 1V 1V	C12, CR24, CR25, T1
- Out	27	38V(6253A) 62V(6255A) 21 V(6281A) 38V(6284A) 62V(6289A) 90V(6294A)	0.4V 0.6V 0.2V 0.4V 0.5V 0.8V	C14, C16, CR26, CR27, R49, T1

Table 5-4. Low Output Voltage Trouble shooting

Step	Action	Response	Probable Cause
1	Turn the VOLTAGE control fully clockwise and disconnect the load		
2	To eliminate the constant current circuit as a cause of the malfunction, remove C R4 cathode or anode lead	a. Output increases b. Output remains low	a. Stage Q2 defective b. Reconnect CR4 and proceed to step 3
3	Check conduction of Q6 and Q7 by connecting a jumper between Q4 emitter (22) and base (18)	a. Output remains low b. Output increases	a. Q6, Q7, CR11 or associated parts defective b. Remove jumper and proceed to step 4
4	Check turnoff of Q4 by shorting Q5 emitter to base	a. Output remains low b. Output increases	a. Q4, CR17, R38 defective b. Remove jumper and proceed to step 5
5	Check turnoff of Q5 by shorting Q3 emitter to collector	a. Output remains low b. Output increases	a. Q5, R31 or associated components defective b. Remove short across Q3 and proceed to step 6

Table 5-4. Low Output Voltage Troubleshooting (Continued)

Step	Action	Response	Probable Cause
6	Check conduction of Q3 by shorting Q1A emitter to collector	a. Output remains low b. Output increases	a. Stage Q3 or Q16 defective b. Remove short and proceed to step 7
7	Remove CR32 anode or cathode lead	a. Output increases b. Output remains low	a. Voltage clamp circuit is defective b. Reconnect CR32. Stage Q1 defective. Check R10, C1 for short and R12, R13 for open.

* See Figure 3-1 for controls and indicators.

Table 5-5. High Output Voltage Troubleshooting

Step	Action	Response	Probable Cause
1	Turn the VOLTAGE control* to approximately mid-range and disconnect the load. If the output voltage should rise to an excessive value with the VOLTAGE control turned ccw, the control could be damaged.		
2	Check turnoff of Q6 and Q7 by shorting collector of Q5 to emitter of Q4	a. Output remains high b. Output decreases	a. Q6, Q7, CR11, R23, R27, R34 defective b. Remove short across Q4 and proceed to step 3
3	Check conduction of Q4 by shorting Q5 emitter to collector	a. Output remains high b. Output decreases	a. Q4, CR17, R38 defective b. Remove short across Q5 and proceed to step 4
4	Open Q3 collector lead Check conduction of Q5 by shorting R33	a. Output remains high b. Output decreases	a. Q5, R31 or associated components defective b. Remove short and proceed to step 5
5	Check turnoff of Q3 by shorting Q3 base to emitter	a. Output remains high b. Output decreases	a. Stage Q3 or Q17 defective b. Remove short and proceed to step 6
6	Remove CR32 anode or cathode	a. Output decreases b. Output remains high	a. Voltage clamp circuit is defective b. Reconnect CR32 and proceed to step 7
7	On rear terminal board, short A6 to (-)	a. Output remains high b. Output decreases	a. Stage Q1 defective b. Remove short across terminals A6 and (-). Check R10 for open and R12, R13 for short.

* See Figure 3-1 for controls and indicators.

Excessive heat or pressure can lift the copper strip from the board. Avoid damage by using a low power soldering iron (50 watts maximum) and following these instructions. Copper that lifts off the board should be cemented in place with a quick drying acetate base cement having good electrical insulating properties.

A break in the copper should be repaired by soldering a short length of tinned copper wire across the break.

Use only high quality rosin core solder when repairing etched circuit boards. NEVER USE PASTE FLUX. After soldering, clean off any excess flux and coat the repaired area with a high quality electrical varnish or lacquer.

When replacing components with multiple mounting pins such as tube sockets, electrolytic capacitors, and potentiometers, it will be necessary to lift each pin slightly, working around the components several times until it is free.

WARNING: If the specific instructions outlined in the steps below regarding etched circuit boards without eyelets are not followed, extensive damage to the etched circuit board will result.

1. Apply heat sparingly to lead of component to be replaced. If lead of component passes through an eyelet in the circuit board, apply heat on component side of board. If lead of component does not pass through an eyelet, apply heat to conductor side of board.

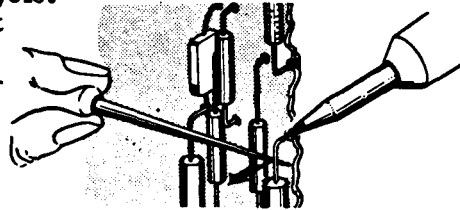

2. Reheat solder in vacant eyelet and quickly insert a small awl to clean inside of hole. If hole does not have an eyelet, insert awl or a #57 drill from conductor side of board.

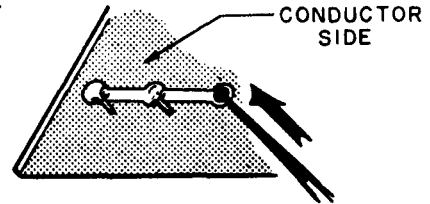

3. Bend clean tinned lead on new part and carefully insert through eyelets or holes in board.

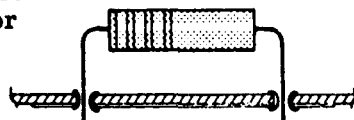

4. Hold part against board (avoid overheating) and solder leads. Apply heat to component leads on correct side of board as explained in step 1.

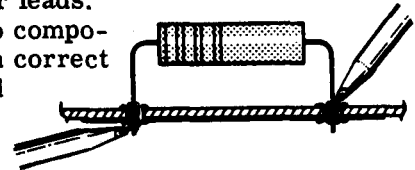

In the event that either the circuit board has been damaged or the conventional method is impractical, use method shown below. This is especially applicable for circuit boards without eyelets.

1. Clip lead as shown below.

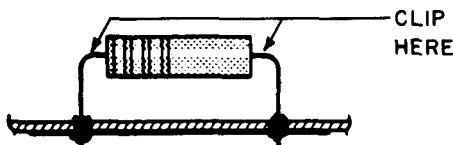

2. Bend protruding leads upward. Bend lead of new component around protruding lead. Apply solder using a pair of long nose pliers as a heat sink.

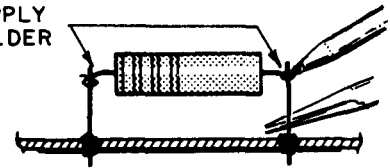

This procedure is used in the field only as an alternate means of repair. It is not used within the factory.

Figure 5-13. Servicing Printed Wiring Boards

5-46 REPAIR AND REPLACEMENT

5-47 Before servicing a printed wiring board, refer to Figure 5-13. The RPSTL for this manual contains a list of replaceable parts. Before replacing a semiconductor device, refer to Table 5-6 which lists the special character-

istics of selected semiconductors. If the device to be replaced is not listed in Table 5-6, the standard manufacturer's part number listed in the RPSTL is applicable. After replacing a semiconductor device, refer to Table 5-7 for checks and adjustments that may be necessary.

Table 5-6. Selected Semiconductor Characteristics

Reference Designator	Characteristics	Ⓢ Stock No.	Suggested Replacement
Q1, 2	Matched differential amplifier. NPN Si Planar. 70 (min.) hFE ic = 1 ma. VCE = 5V. Ico 0. 01µa @ Vcbo = 5V.	1854-0229	2N2917 G. E.
Q11	NPN Power. hFE = 35 (min.) @ Ic = 4A, VCE = 4V.	1854-0221	2N4045
Q6, 7(16)		1854-0228	2N3055 R. C. A.
CR1-5, 19, 20, 30, 32	Si. rectifier, 200ma, 200prv	1901-0033	1N485B Sylvania
VR3	Diode, zener, 4. 22V, 400mW	1902-3070	1N749 Motorola
VR4 , 5	Diode, zener, 4. 3V, 1W	1902-0797	1N3824 Motorola

Table 5-7. Checks and Adjustments After Replacement of Semiconductor Devices

Reference	Function	Check	Adjust
Q1	Constant voltage differential amplifier	Constant voltage (CV) line and load regulation. Zero volt output.	R6 or R8
Q2	Constant current differential amplifier	Constant current (CC) line and load regulation. Zero current output.	R25 or R28
Q3, Q16	Mixer amplifier	CV/CC load regulation. CV transient response.	R30.
Q4, Q5	Error amplifiers and driver	CV/CC load regulation.	
Q6, Q7	Series regulator	CV/CC load regulation.	
Q8, Q9	Reference regulator	Reference circuit line regulation.	R46
Q10	Clamp circuit	CC load regulation.	
Q11-Q15	Meter circuit	Meter zero. Voltmeter/ammeter tracking.	R63, R72 R56
CR1, CR2	Limiting diodes	CV load regulation.	
CR3, CR4, CR5	OR-gate diodes and limiting diode	CV/CC load regulation.	

Table 5-7. Checks and Adjustments After Replacement of Semiconductor Devices (Continued)

Reference	Function	Check	Adjust
CR8-CR10	Forward bias regulator	Voltage across each diode 0.6 to 0.9 volts.	
CR22-CR27	Rectifier diodes	Voltage across appropriate filter capacitor.	
CR34	Protection diode	Output voltage	
VR1	Positive reference voltage	Positive reference voltage (+6.2V).	
VR2	Negative reference voltage	Negative reference voltage (-6.2V).	
VR4	Bias voltage	4.4V	

Table 5-8. Calibration and Adjustment Summary

Adjustment or Calibration *	Paragraph	Control Device	Adjustment or Calibration	Paragraph	Control Device
Meter Zero	5-50	Pointer	"Current" Programming Current	5-61	R19
Voltmeter Tracking	5-52	R63 and R72	Reference Circuit Line Voltage Adjustment	5-63	R46
Ammeter Tracking	5-54	R56	Negative Reference Load Adjustment	5-64	Replace VR2
"Zero" Volt Output	5-57	R6 or R8	Positive Reference Load Adjustment	5-65	Replace VR1
"Voltage" Programming Current	5-58	R13	Transient Response	5-66	R30
"Zero" Current Output	5-60	R25 or R28			

* See Figure 3-1 for controls and indicators.

5-47A.1 **FUSE REPLACEMENT** (Figures 1-1,3-1)

5-47A.2 Replace fuses by using the following procedure:

- a. Turn off instrument power.
- b. Remove fuse holder by inserting screwdriver blade into fuse holder slot on front panel and turning ccw.
- c. Remove defective fuse from holder, and replace fuse.
- d. Replace fuse holder.
- e. Restore power.

5-47A.3 **COVER REMOVAL**

5-47A.4 When it is necessary to repair or adjust the power supply, one or more covers will have to be removed. Refer to Figure 5-14 and the following steps for cover removal procedure.

- a. Top Cover
Remove four top cover screws, and lift cover to remove.
- b. Bottom Cover
Remove four bottom cover screws along with rubber feet, and lift cover to remove.
- c. Front Panel
 1. Remove six sets of knobs (METER, VOLTAGE and CURRENT controls) for both power supplies.
 2. Remove nut attaching meter switches to front panel.

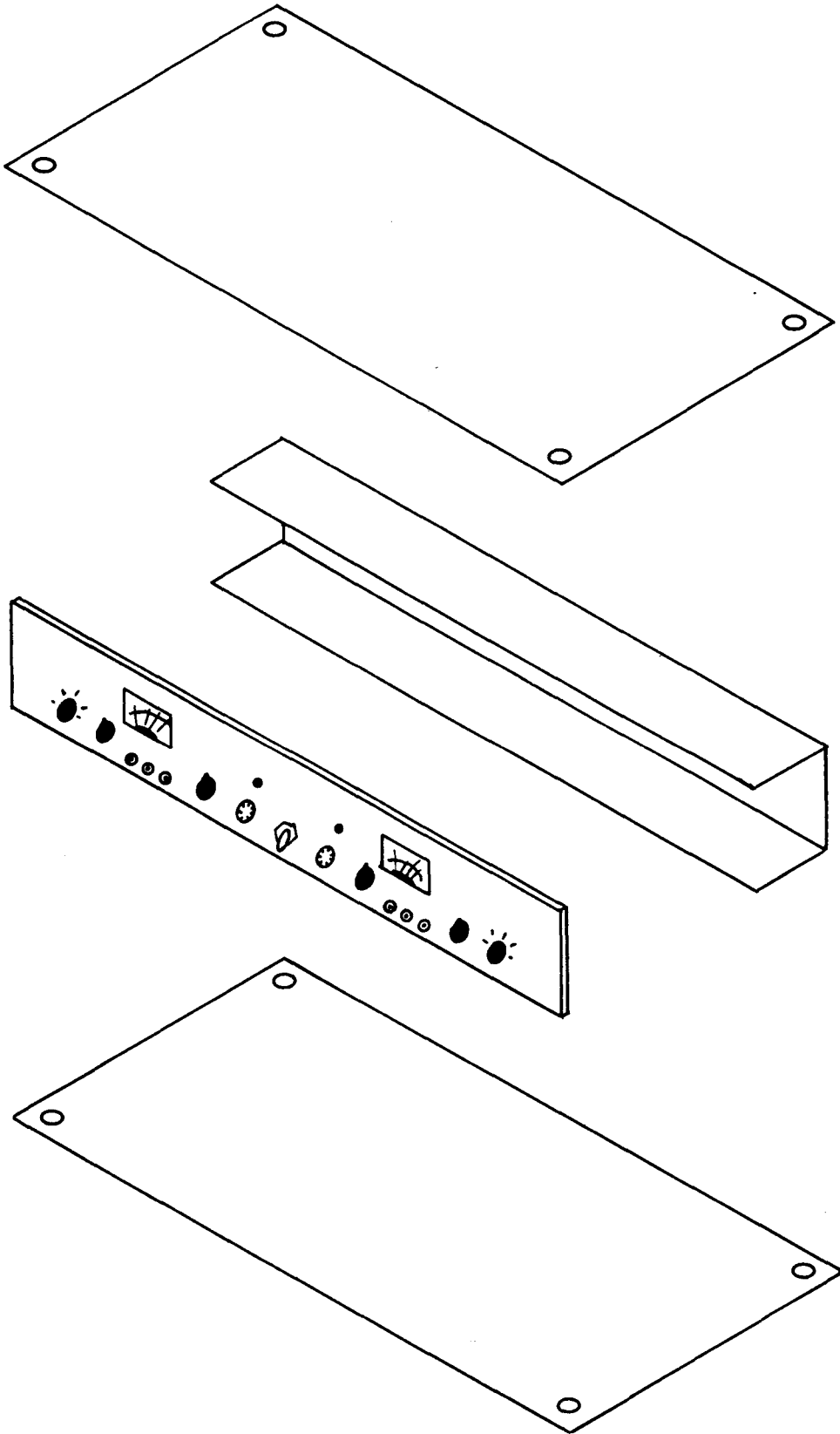

Figure 5-14. Model 6255A Modular Cabinet

CAUTION

Exercise care when pulling front panel forward to avoid damaging any of the components or connecting wiring.

3. Carefully pull front panel forward, freeing it from shafts on the **METER, VOLTAGE** and **CURRENT** programming controls.

d. **Top Red Rear Cover**

Remove two screws from ends of back of unit, and slide cover to rear for removal.

5-47A.5 **POWER CABLE REPLACEMENT** (FO-1)

5-47A.6 When it is necessary to replace the power cable, turn instrument power off, unplug power cord, and remove top cover. Replace power cable by using the following procedure.

- a. Unsolder three power cable leads (white, black and green) from terminal and ground.
- b. Remove cable from rear of power supply .
- c. Install new power cable, and solder leads to terminal and ground.
- d. Replace top cover.

5-47A.7 **SWITCH S1 REPLACEMENT** (Figures 1-1, 3-1 FO-1, FO-2)

5-47A.8 When it is necessary to replace **LINE ON** switch S1, turn instrument power off, unplug power cord, and remove top cover. Replace switch S1 by using the following procedure.

- a. Unsolder four leads from terminals on switch, and tag leads.
- b. Remove nut securing switch to front panel.
- c. Install new switch in panel, and resolder leads.
- d. Replace top cover.

5-47A.9 **TRANSFORMER T1 REPLACEMENT** (Figures 4-2, FO-1, FO-2)

5-47A.10 When it is necessary to

replace transformer T1, use the following procedure.

a. Turn instrument power off, unplug power cord, and remove top and bottom covers for access to transformer T1.

b. Use following steps for replacement of transformer on left P.C. board:

1. Remove hardware and bracket from transformer on left side of case.

2. Remove two nuts from upper right side of transformer.

3. Remove four screws from bottom of P.C. board, securing transformer to board.

4. Unsolder and tag transformer leads from P.C. board, and carefully remove transformer.

5. Place new transformer on P.C. board with spacer nuts and screws.

6. Solder leads onto P.C. board.

7. Install nuts on top, right of transformer and bracket to left side of case.

c. Use following steps for replacement of transformer on right P.C. board.

1. Remove six top nuts securing transformer to horizontal braces.

2. Remove upper screw in vertical bracket securing it to horizontal brace.

3. Remove two screws securing Overvoltage Protection Crowbar P.C. board to horizontal brace on left of transformer. (Carefully place this P.C. board back towards rear of power supply).

4. Remove two screws and nuts securing horizontal braces to right side of case.

5. Remove horizontal braces.

6. Remove screws and spacer nuts securing transformer to P.C. board.

7. Unsolder and tag transformer leads from P.C. board, and carefully remove transformer.

8. Place new transformer on P.C. board with spacer nuts and screws.

9. Solder leads onto P.C. board.

10. Mount horizontal braces over transformer and secure top with six mounting nuts.

11. Replace screws and nuts at right side of case.

12. Re-install Crowbar P.C. board on horizontal brace.

13. Re-install screw in vertical bracket securing bracket to horizontal brace.

5-47A.11 OVERVOLTAGE PROTECTION CROWBAR P.C. BOARD REPLACEMENT (FO-1, FO-2, 3-13)

5-47A.12 When it is necessary to replace the Overvoltage Protection Crowbar P.C. boards, turn instrument power off, unplug power cord, and remove top cover. Use caution when removing the P.C. boards to avoid damaging mounted components.

- a. Remove two screws securing P.C. board.
- b. Unsolder and tag leads from P.C. board. Remove P.C. board from chassis.
- c. Solder leads to replacement P.C. board.
- d. Mount left P.C. board on horizontal brace at top of case.
- e. Mount right P.C. board on right side of case.

5-47A.13 MAIN LEFT P.C. BOARD REPLACEMENT (VIEWED FROM FRONT OF POWER SUPPLY) (FO-1, FO-2)

5-47A.14 When it is necessary to replace the main left P.C. board assembly, turn instrument power off, unplug power cord, and remove top and bottom covers and front panel. Use caution when removing the P.C. board to avoid damaging mounted components. Replace the P.C. board by using the following procedure.

- a. Unsolder and tag leads from the following components mounted on left half of front panel.
 1. Crowbar adjust.
 2. Meter.

3. Power supply output terminals

4. Fuse cartridge F1.

5. Neon lamp DS1.

b. Remove the left Overvoltage Protection Crowbar P.C. board from the case by removing two screws.

c. Remove bottom plate in center of power supply that is attached to both main P.C. boards by four screws accessible from the top.

———— CAUTION ————

Note and mark locations of power transistors before removing them.

- d. Remove seven nuts and screws securing heat sink and power transistors to P.C. board.
- e. Unsolder leads attaching three power transistors to P.C. board.
- f. Remove single screw attaching left side of P.C. board to case of power supply.
- g. Remove two top nuts securing transformer to side of case.
- h. Remove two nuts securing transformer to horizontal braces.
- i. Remove four nuts from top of transformer on right side of power supply.
- j. Remove two screws and nuts securing horizontal braces to right side of case.

———— CAUTION ————

P.C. board assembly to avoid damaging P.C. board or its components.

k. Carefully slide P.C. board assembly to right and downward, holding it by the transformer.

l. Reverse steps k through a for reassembly.

5-47A.15 MAIN RIGHT P.C. BOARD REPLACEMENT (VIEWED FROM FRONT OF POWER SUPPLY) (FO-1, FO-2)

5-47A.16 When it is necessary to replace the main right P.C. board assembly, turn instrument power off, unplug power cord, and remove top and bottom covers and front panel. Use caution when removing the P.C. board to avoid damaging mounted components. Replace the P.C. board by using the following procedure:

a. Unsolder and tag leads from the following components mounted on right half of front panel.

1. Crowbar adjust.
2. Meter.
3. Power supply output terminals.
4. Fuse Cartridge F1.
5. Neon lamp DS1.

b. Remove the right Overvoltage Protection Crowbar P.C. board from the case by removing two screws.

c. Remove bottom plate in center of power supply that is attached to both main P.C. boards by four screws accessible from the top.

CAUTION

Note and mark locations of power transistors before removing them.

d. Remove seven nuts and screws securing heat sink and power transistors to P.C. board.

e. Unsolder leads attaching three power transistors to P.C. board.

f. Remove single screw attaching right side of P.C. board to case of power supply.

g. Remove four top nuts securing transformer to horizontal braces.

h. Remove two nuts from top of transformer on left side of power supply securing transformer to horizontal braces.

i. Remove two screws and nuts securing horizontal braces to right side of case.

CAUTION

Exercise care when removing P.C. board assembly to avoid damaging P.C. board or its components.

j. Carefully slide P.C. board assembly to left and downward, holding it by the transformer.

k. Reverse steps j through a for reassembly.

5-47A.17 CAPACITOR C14 REPLACEMENT
(Figures 4-2, FO-1 FO-2)

5-47A.18 When it is necessary to replace capacitor C14, turn instrument power off, unplug power cord, and remove top and bottom covers. Replace capacitor in either half of the power supply by using the following procedure.

a. Remove two screws under P.C. board securing capacitor to board.

b. Remove capacitor from top of P.C. board.

c. Reverse steps b and c to install new capacitor.

5-47A.19 CAPACITORS C5, C6 REPLACEMENT
(FO-1, FO-2)

5-47A.20 When it is necessary to replace capacitors C5 or C6, turn instrument power off, unplug power cord, and remove top and bottom covers. Replace capacitors in either half of the power supply by using the following procedure.

a. Remove two screws securing Overvoltage Protection Crowbar P.C. board to allow access to capacitors.

b. Unsolder and remove defective capacitor.

c. Install replacement capacitor.

d. Re-install Overvoltage Protection Crowbar P.C. board, and top and bottom covers.

5-47A.21 POWER TRANSISTOR Q4, Q6 REPLACEMENT (FO-1, FO-2)

5-47A.22 When it is necessary to replace a power transistor, turn instrument power off, unplug power cord, and remove top and bottom covers. Replace transistor by using the following procedure.

- a. Remove hardware securing crowbar P.C. board, and re-position board without unsoldering to provide access to Q4 or Q6.
- b. Remove hardware attaching transistor to heat sink.
- c. Unsolder transistor leads from P.C. board.
- d. Carefully remove transistor, complete with mica insulator.
- e. Install new transistor, using new mica insulator.
- f. Solder transistor leads to P.C. board.
- g. Re-install crowbar P.C. board.
- h. Refer to paragraph 5-16 and 5-35, and check cv/cc load regulation.
- i. Re-install top and bottom covers.

5-47A.23 POWER TRANSISTOR Q7 REPLACEMENT (FO-1, FO-2)

5-47A.24 When it is necessary to replace power transistor Q7, turn instrument power off, unplug power cord, and remove top and bottom covers. Replace Q7 by using the following procedure.

- a. Remove hardware attaching transistor to heat sink.
- b. Unsolder transistor leads from P.C. board.
- c. Carefully remove transistor, complete with mica insulator.
- d. Install new transistor, using new mica insulator.
- e. Solder transistor leads to P.C. board.
- f. Refer to paragraphs 5-16 and 5-35, and check cv/cc regulation.
- g. Re-install top and bottom covers.

5-47A.25 TRANSISTOR Q3 REPLACEMENT (FO-1, FO-2)

5-47A.26 When it is necessary to replace Q3, turn instrument power off, unplug power cord, and remove top and bottom covers. Replace Q3 by using the following procedure.

- a. Remove hardware securing crowbar P.C. board, and re-position to provide access to Q3.
- b. Unsolder Q3 from P.C. board.
- c. Install new transistor, and solder in place.
- d. Re-install crowbar P.C. board.
- e. Refer to paragraph 5-16 and 5-35, and check cv/cc load regulation.
- f. Refer to paragraph 5-31, and check cv transient response.
- g. Re-install top and bottom covers.

5-47A.27 VOLTAGE/CURRENT PROGRAMMING CONTROL REPLACEMENT (Figures 4-2, FO-1, FO-2)

5-47A.28 When it is necessary to replace either a Voltage or Current Programming Control, turn instrument power off, unplug power cord, and remove top and bottom covers. To replace programming controls, use the following procedure.

- a. Remove front panel knobs from all four programming control shafts.
- b. Remove front panel, leaving all leads attached to front panel controls/indicators.
- c. Unsolder potentiometers from P.C. board.
- d. Carefully install new programming control potentiometer.
- e. Re-install knobs on shaft.
- f. Re-install top and bottom covers.

5-47A.29 SILICON RECTIFIER CR19 REPLACEMENT (FO-1, FO-2)

5-47A.30 When it is necessary to replace rectifier CR19, turn instrument power off, unplug power cord, and remove top and bottom covers. Replace rectifier in either half of power supply by

using the following procedure.

- a. Remove hardware securing crowbar P.C. board, and reposition without unsoldering to provide access to CR19.
- b. Unsolder and remove defective rectifier.
- c. Install replacement rectifier.
- d. Re-install Overvoltage Protection Crowbar P.C. board, and top and bottom covers.

5-47A.31 METER SWITCH S2 REPLACEMENT
(Figures 1-1, 3-1, FO-1, FO-2)

5-47A.32 When it is necessary to replace switch S2, turn instrument power off, unplug power cord, and remove top cover to provide access to switch terminals. Replace switch S2 by using the following procedure.

- a. Remove knob from meter shaft on front panel.
- b. Remove nut securing METER switch to front panel.
- c. Remove METER switch from front panel and position switch to facilitate unsoldering of leads from switch terminals.
- d. Reverse steps c through a to install new METER switch.

5-47A.33 METER REPLACEMENT (Figures 1-1, 3-1, FO-1, FO-2)

5-47A.34 When it is necessary to replace a meter, turn instrument power off, unplug power cord, and remove top cover to provide access to the two plastic brackets (bezels) securing each meter to front panel. Replace meters by using the following procedure.

- a. Unsolder and tag two leads attached to back of meter.

CAUTION

Exercise extreme care when removing or replacing a meter to avoid damage.

- b. Avoid cracking or breaking

plastic bezel by carefully prying it open sufficiently to unsnap it from meter case.

- c. Carefully install new meter, and solder two leads.

5-47A.35 SHUNT RESISTOR (R81, R82, OR R83) REPLACEMENT (FO-1)

5-47A.36 When it is necessary to replace a shunt resistor, turn instrument power off, unplug power cord, and remove red rear cover to provide access to resistors.

- a. Unsolder resistor leads and remove two screws securing set of shunt resistors to be replaced.
- b. Remove defective resistor(s); re-install replacement resistors with screws, and solder.
- c. Replace red rear cover.

5-47A.37 FUSE HOLDER ASSEMBLY REPLACEMENT (Figures 1-1, 3-1, FO-1, FO-2)

5-47A.38 When it is necessary to replace a defective fuse holder assembly, turn instrument power off, unplug power cord, and remove top cover. To replace fuse holder assembly, use the following procedure.

- a. Remove fuse from front panel.
- b. Loosen plastic nut attaching fuse assembly to front panel.
- c. Unsolder two leads from fuse holder terminals.
- d. Install new fuse holder, and reverse above steps c through a for re-assembly.
- e. Replace top cover.

5-47A.39 NEON LAMPDS1 REPLACEMENT
(Figures 1-1, 3-1, FO-1, FO-2)

5-47A.40 When it is necessary to replace a defective neon lamp, turn instrument power off, unplug power cord, and remove top cover. To replace a neon lamp, use the following procedure.

- a. Unsolder two leads from lamp assembly behind front panel.
- b. Remove clip from behind panel, and pull lamp out through front of panel.

- c. Insert new lamp, install new clip, and solder leads to terminals.
- d. Replace top cover.

5-47A.41 CROWBAR ADJUST POTENTIOMETER R5 REPLACEMENT (Figures 1-1, 3-1, FO-1, FO-2)

5-47A.42 When it is necessary to replace a defective crowbar adjust potentiometer, turn instrument power off, unplug power cord, and remove top cover. To replace a crowbar adjust potentiometer, use the following procedure.

- a. Unsolder two leads from potentiometer terminals behind panel.
- b. Unbolt potentiometer shaft from back of panel.
- c. Unbolt shaft from potentiometer.
- d. Remove nut supplied with new potentiometer.
- e. Install shaft on new potentiometer.
- f. Bolt potentiometer shaft to back of panel.
- g. Solder leads to potentiometer.
- h. Replace top cover.

5-48 ADJUSTMENT AND CALIBRATION

5-49 Adjustment and calibration may be required after performance testing, troubleshooting, or repair and replacement. Perform only those adjustments that affect the operation of the faulty circuit and no others. Table 5-8 summarizes the adjustments and calibrations contained in the following paragraphs.

5-50 **METER ZERO** (See Figure 3-1 for controls and indicators.)

5-51 The meter pointer must rest on the zero calibration mark on the meter scale when the instrument is at normal operating temperature, resting in its normal operating position, and the instrument is turned off. To zero-set the meter proceed as follows:

- a. Turn on instrument and allow it to come up to normal operating temperature (about 20 minutes).
- b. Turn the instrument off. Wait two minutes for power supply capacitors to discharge completely.
- c. Rotate adjustment screw on front of meter clockwise until the meter pointer is to the left of zero and further clockwise rotation will move the pointer up scale towards zero.

d. Turn the adjustment screw clockwise until the pointer is exactly over the zero mark on the scale. If the screw is turned too far, repeat steps c and d.

e. Turn meter adjustment screw counterclockwise about 15 degrees to break contact between adjustment screw and pointer mounting yoke, but not far enough to move the pointer back down scale. If screw is turned too far, as shown by the needle moving, repeat the procedure. The meter is now zero-set for best accuracy and mechanical stability.

5-52 **VOLTMETER TRACKING** (See Figure 3-1 for controls and indicators.)

5-53 To calibrate voltmeter tracking, proceed as follows:

- a. To electrically zero meter, set METER switch to highest current position and, with supply on and no load connected, adjust R63 until front panel meter reads zero.
- b. Connect differential voltmeter across supply, observing correct polarity.
- c. Set METER switch to highest voltage range and turn on supply. Adjust VOLTAGE control until differential voltmeter reads exactly the maximum rated output voltage.
- d. Adjust R72 until front panel meter also indicates maximum rated output voltage.

5-54 **AMMETER TRACKING** (See Figure 3-1 for controls and indicators.)

5-55 To calibrate ammeter tracking proceed as follows:

- a. Connect test setup shown on Figure 5-4 leaving switch S1 open.
- b. Turn VOLTAGE control fully clockwise and set METER switch to highest current range.
- c. Turn on supply and adjust CURRENT controls until differential voltmeter reads 1.0Vdc.
- d. Adjust R56 until front panel meter indicates exactly the maximum rated output current.

5-56 **CONSTANT VOLTAGE PROGRAMMING CURRENT** (See Figure 3-1 for controls and indicators.)

5-57 To calibrate the zero volt programming accuracy, proceed as follows:

- a. Connect differential voltmeter between +S and -S terminals.
- b. Short out voltage controls by connecting jumper between terminals A6 and -S.
- c. Rotate CURRENT controls fully clockwise and turn on supply.
- d. Observe reading on differential voltmeter.
- e. If it is more positive than 0 volts, shunt resistor R6 with decade resistance box.

f. Adjust decade resistance until differential voltmeter reads zero, then shunt R6 with resistance value equal to that of the decade resistance.

g. If reading of step d is more negative than 0 volts, shunt resistor R8 with the decade resistance box.

h. Adjust decade resistance until differential voltmeter reads zero then shunt R8 with resistance value equal to that of the decade box.

5-58 To calibrate the constant voltage programming current, proceed as follows:

a. Connect a 0.1%, 1/2 watt resistor between terminals -S and A6 on rear barrier strip. Resistor value to be as follows:

<u>Model</u>	6253A, 6284A	6255A, 6289A	6281A	6294A
<u>Resistance</u>	4K Ω	8K Ω	1.5K Ω	18K Ω

b. Disconnect jumper between A6 and A8 (leaving A6 and A7 jumpered) on rear terminal barrier strip.

c. Connect a decade resistance in place of R13.

d. Connect a differential voltmeter between +S and -S and turn on supply.

e. Adjust decade resistance box so that differential voltmeter indicates maximum rated output voltage within the following tolerances:

<u>Model No.</u>	6253A, 6284A	6255A, 6289A
<u>Tolerance (Vdc)</u>	± 0.4	± 0.8

<u>Model No.</u>	6281A	6294A
<u>Tolerance (Vdc)</u>	± 0.15	± 1.2

f. Replace decade resistance with resistor of appropriate value in R13 position.

5-59 **CONSTANT CURRENT PROGRAMMING CURRENT (See Figure 3-1 for controls and indicators.)**

5-60 To calibrate the zero current programming accuracy, proceed as follows:

a. Connect differential voltmeter between +S and -S terminals.

b. Short out current controls by connecting jumper between terminals A1 and A5.

c. Rotate VOLTAGE control (s) fully clockwise and turn on supply.

d. Observe reading on differential voltmeter.

e. If it is more positive than 0 volts, shunt resistor R25 with a decade resistance box.

f. Adjust decade resistance until differential voltmeter reads zero, then shunt R25 with resistance value equal to that of decade resistance.

g. If reading of step d is more negative than 0 volts, shunt resistor R28 with decade resistance.

h. Adjust decade resistance until differential voltmeter reads zero, then shunt R28 with resistance value equal to that of decade box.

5-61 To calibrate the constant current programming current, proceed as follows:

a. Connect power supply as shown in Figure 5-4.

b. Remove strap between A3 and A4 (leaving A4 and A5 jumpered).

c. Connect a 0.1%, 1/2 watt resistor between A1 and A5. Resistor value to be as follows:

<u>Model No.</u>	6253A, 6284A	6255A, 6289A
<u>Resistance</u>	1.5K Ω	750 Ω

<u>Model No.</u>	6281A	6294A
<u>Resistance</u>	1K Ω	1K Ω

d. Connect decade resistance box in place of R19.

e. Set METER switch to highest current range and turn on supply.

f. Adjust the decade resistance so that the differential voltmeter indicates 1.0 ± 0.01 Vdc.

g. Replace decade resistance with appropriate value resistor in R19 position.

5-62 REFERENCE CIRCUIT ADJUSTMENTS

5-63 Line Regulation. To adjust the line regulation capabilities of the instrument proceed as follows:

a. Connect the differential voltmeter between +S (common) and 33 (positive).

b. Connect variable voltage transformer between supply and input power source.

c. Adjust line to 105 Vac.

d. Connect decade resistance in place of R46.

e. Turn on supply and adjust VOLTAGE control(s) for maximum rated output voltage.

f. Adjust decade resistance so that voltage indicated by differential voltmeter does not change more than the following as input line voltage is varied from 105 to 125Vac:

<u>Model No.</u>	6253A, 6284A	6255A, 6289A
<u>Variation (mVdc)</u>	0.95	0.81

<u>Model No.</u>	6281A	6294A
<u>Variation (mVdc)</u>	1.24	0.75

g. Replace decade resistance with appropriate value resistor in R46 position.

5-64 CONSTANT VOLTAGE TRANSIENT RESPONSE

5-65 To adjust the transient response, proceed as follows:

a. Connect test setup as shown in Figure 5-8.

b. Repeat steps a through e as outlined in Paragraph 5-31.

c. Adjust R30 so that the transient response is as shown in Figure 5-9.

APPENDIX A

REFERENCES

AR 750-58	Painting, Camouflage Painting and Marking of Army Material.
DA PAM 310-1	Consolidated Index of Army Publications and Blank Forms.
SB 11-573	Painting and Preservation Supplies Available for Field Use for Electronics Command Equipment.
TB SIG-222	Solder and Soldering.
TB 43-0116	Identification of Radioactive Items in the Army Supply System.
TB 43-0118	Field Instructions for Painting and Preserving Electronics Command Equipment Including Camouflage Pattern Painting of Electrical Equipment Shelters.
TB 746-10	Field Instructions for Painting and Preserving Electronics Command Equipment.
TM 38-750	The Army Maintenance Management System (TAMMS).
TM 740-90-1	Administrative Storage of Equipment.
TM 750-244-2	Procedures for Destruction of Electronics Materiel to Prevent Enemy Use (Electronics Command).
TM 11-6130-416-24P EE010-BJ-MMA-010/E154 DCDUAL T.O. 35C1-2-847-4	Organizational, Direct Support and General Support Repair Parts and Special Tools List (Including Depot Repair Parts and Special Tools List) for Power Supply, Dual DC (Hewlett-Packard Model 6255A) (NSN 6130-00-065-6811!c To be published.
TM 11-6625-1541-15	Technical Manual True RMS Meter AN/USM-224
TM 11-6625-654-14	Operator, Organizational, Direct Support, General Support, and Depot Maintenance Manual Including Repair Parts and Special Tool Lists for Multimeter AN/USM-223
TM 11-6625-2568-14	Operator, Organizational, Direct Support, and General Support Maintenance Manual for CLscilloscope AN/USM-281C (NSN 6625-00-106-9622). To be published.
*T.O. 33A1-13-432-1	Technical Manual: Oscilloscope AN/USM-338

*Refer to Air Force Index NIRT 0-1-31

APPENDIX B

MAINTENANCE ALLOCATIONSection I. **INTRODUCTION**

B-1. **General.** This appendix provides a summary of the maintenance operations for the DC Power Supply DPR Series, Model 6255A. It authorizes categories of maintenance for specific maintenance functions on repairable items and components and the tools and equipment required to perform each function.

B-2. **Maintenance Concept.** Two levels of maintenance shall be utilized for the equipment as follows:

Organizational Level**Depot Level.**

a. **Organization Maintenance.** That maintenance which is the responsibility of and performed by a using organization on its assigned equipment. Its phases normally consist of inspecting, servicing, lubricating, and adjusting, and the replacement of parts, minor assemblies and subassemblies. This level is designated by an O in the Maintenance Category columns in Section II.

b. **Depot Maintenance.** That maintenance which is the responsibility of and performed by designated maintenance activities, to augment stocks of serviceable material, and to support lower level activities by the use of more extensive shop facilities, equipment and personnel of higher technical skills than are available at the lower level of maintenance. Its phases normally consist of inspection, test, repair, modification, alteration, modernization, conversion, overhaul reclamation, or rebuild of parts, assemblies, subassemblies, components, equipment end items, and weapon systems; and the manufacture of critical non-available parts. Depot Maintenance is normally accomplished in fixed shops. This level is designated by a D in the Maintenance Category columns in Section II.

B-3. **Maintenance Function.** Maintenance functions for the DC Power Supply DPR Series, Model 6255A are defined as follows:

a. **Inspect.** To determine the serviceability of an item by comparing its physical, mechanical, and/or electrical characteristics with established standards through examination.

b. **Test.** To verify serviceability and to detect incipient failure by measuring the mechanical or electrical characteristics of an item and comparing those characteristics with prescribed standards.

c. **Service.** Operations required periodically to keep an item in proper operating condition, i.e., to clean (decontaminate), to preserve, to drain, to paint, or to replenish fuel, lubricants, hydraulic fluids, or compressed air supplies.

d. **Adjust.** To maintain, within prescribed limits, by bringing into proper or exact position, or by setting the operating characteristics to the specified parameters.

e. **Align.** To adjust specified variable elements of an item to bring about optimum or desired performance.

f. **Calibrate.** To determine and cause corrections to be made or to be adjusted on instruments or test measuring and diagnostic equipments used in precision measurement. Consists of comparisons of two instruments, one of which is a certified standard of known accuracy, to detect and adjust any discrepancy in the accuracy of the instrument being compared.

g. **Install.** The act of emplacing, seating, or fixing into position an item, part, or module (component or assembly) in a manner to allow the proper functioning of the equipment or system.

h. **Replace.** The act of substituting a serviceable like type part, subassembly, or module (component or assembly) for an unserviceable counterpart.

i. **Repair.** The application of maintenance service (inspect, test, service, adjust, align, calibrate, or replace) or other maintenance actions (welding, grinding, riveting, straightening, facing, remachining, or resurfacing) to restore serviceability to an item by correcting specific damage, fault, malfunction, or failure in a part, subassembly, module (component or assembly), end item, or system.

j. **Overhaul.** That maintenance effort (service/action) necessary to restore an item to a completely serviceable/operational condition as prescribed by maintenance standards (i.e., DM WR) in appropriate technical publications. Overhaul is normally the highest degree of maintenance performed by the Army. Overhaul does not normally return an item to like new condition.

k. **Rebuild.** Consists of those services/actions necessary for the restoration of unserviceable equipment to a like new condition in accordance with original manufacturing standards. Rebuild is the highest degree of materiel maintenance applied to Army equipment. The rebuild operation includes

the act of returning to zero those age measurements (hours, miles, etc.) considered in classifying Army equipments/components.

B-4. Column Entries.

a. Column 1, Group Number. Column 1 lists group numbers, the purpose of which is to identify components, assemblies, subassemblies, and modules with the next higher assembly.

b. Column 2, Component/Assembly. Column 2 contains the noun names of components, assemblies, subassemblies, and modules for which maintenance is authorized.

c. Column 3, Maintenance Function. Column 3 lists the functions to be performed on the item listed in Column 2. When items are listed without maintenance functions, it is solely for the purpose of having the group numbers in the MAC and RPSTL coincide.

d. Column 4, Maintenance Category. Column 4 specifies by the listing of a worktime figure in the appropriate subcolumn(s), the lowest level of maintenance authorized to perform the function listed in Column 3. This figure represents the active time required to perform that maintenance function at the indicated category of maintenance. If the number or complexity of the tasks within the listed maintenance function vary at different maintenance categories, appropriate worktime figures will be shown for each category. The number of task-hours specified by the worktime figure represents the average time required to restore an item (assembly, subassembly, component, module, end item or system) to a serviceable condition under typical field operating conditions. This time includes preparation time, troubleshooting time, and quality assurance/quality control time in addition to the time required to perform the specific tasks identified for the maintenance functions authorized in the maintenance allocation chart. Subcolumns of Column 4 are as follows:

- C Operator/Crew
- O Organizational

- F Direct Support
- H General Support
- D Depot.

e. Column 5, Tools and Equipment. Column 5 specifies, by code, those common tool sets (not individual tools), and special tools, test, and support equipment required to perform the designated function.

f. Column 6, Remarks. Column 6 contains an alphabetic code which leads to the remark in Section IV, Remarks, which is pertinent to the item opposite the particular code.

B-5. Tool and Test Equipment Requirements (Section III).

a. Tool or Test Equipment Reference Code. The numbers in this column coincide with the numbers used in the tools and equipment column of the MAC. The numbers indicate the applicable tool or test equipment for the maintenance functions.

b. Maintenance Category. The codes in this column indicate the maintenance category allocated the tool or test equipment.

c. Nomenclature. This column lists the noun name and nomenclature of the tools and test equipment required to perform the maintenance functions.

d. National/NATO Stock Number. This column lists the National/NATO stock number of the specific tool or test equipment.

e. Tool Number. This column lists the manufacturer's part number of the tool followed by the Federal Supply Code for manufacturers (5-digit) in parentheses.

B-6. Remarks (Section IV).

a. Reference Code. This code refers to the appropriate item in Section II, Column 6.

b. Remarks. This column provides the required explanatory information necessary to clarify items appearing in Section II.

**SECTION II. MAINTENANCE ALLOCATION CHART
FOR
DC POWER SUPPLY DPR SERIES, MODEL 6255A**

(1) Group Number	(2) Component/Assembly	(3) Maintenance Function	(4) Maintenance Category					(5) Tools and Equip.	(6) Remarks
			C	O	F	H	D		
00	POWER SUPPLY, HP 6255A	INSPECT		0.1					A
		TEST		0.1				1,6	B
		REPAIR		0.1				1,6	C
		TEST					1.0	1,2,3, 4,6,8	F
		ADJUST					0.5	2,4,6, 8	
		CALIBRATE OVERHAUL					1.5 60.0	2,6,8 1,2,3, 4,5,6, 7,8	
01	PRINTED CIRCUIT BOARDS	REPAIR					80.0	1,2,3, 4,5,6, 7,8	
						1.5	1,2,3, 4,5,6, 7,8	D	
02	FRONT PANEL ASSEMBLY	CALIBRATE					1.0	2,6,8	E
		REPAIR					1.5	1,2,3, 4,5,6, 7,8	D
03	CHASSIS ASSEMBLY	REPAIR					1.5	1,2,3, 4,5,6, 7,8	D

**SECTION III. TOOL AND TEST EQUIPMENT REQUIREMENTS
FOR
DC POWER SUPPLY DPR SERIES, MODEL 6255A**

Tool or Test Equipment Ref Code	Maintenance Category	Nomenclature	National/NATO Stock Number	Tool Number
1	O,D	DIGITAL MULTIMETER, AN/USM-451	6625-00-168-0585	
2	D	VOLTMETER DIFFERENTIAL, FLUKE 893A	6625-00-488-4039	
3	D	OSCILLATOR, AUDIO, HP 200CD	6625-00-518-4659	
4	D	OSCILLOSCOPE, OS-261/U	6625-00-127-0079	
5	D	TOOL KIT, PRINTED CIRCUIT CARD REPAIR	3439-00-196-0703	
6	O,D	TOOL KIT, TK-105/G	5180-00-610-8177	
7	D	TOOL KIT, TK-100/G	5180-00-605-0079	
8	D	ACCESSORIES KIT, POWER SUPPLY REPAIR		

**SECTION IV. REMARKS
FOR
DC POWER SUPPLY DPR SERIES, MODEL 6255A**

Reference Code	Remarks
A	VISUAL EXTERNAL
B	TEST IS TURN-ON SEQUENCE
C	ORGANIZATIONAL REPAIR IS LIMITED TO FUSE REPLACEMENT
D	REPAIR BY MOUNTED COMPONENT REPLACEMENT
E	CALIBRATION IS PERFORMED FOR VOLTMETER AND AMMETER
F	PERFORMANCE TEST IS USED AS AN INSPECTION CHECK AND AFTER MAJOR REPAIRS. APPROPRIATE PORTIONS OF THIS TEST ARE APPLIED AS OPERATION CHECKS AFTER MINOR REPAIRS.

APPENDIX C

COMPONENTS OF END ITEM LIST

Section I. **INTRODUCTION**

C-1 Scope. This appendix lists integral components of and basic issue items for the HP 6255A to help you inventory items required for safe and efficient operation.

C-2 General. This Components of End Item List is divided into the following sections:

a. Section II. Integral Components of the End Item. These items, when assembled, comprise the HP 6255A and must accompany it whenever it is transferred or turned in. The illustrations will help you identify these items.

b. Section III. Basic Issue Items. These are the minimum essential items required to place the HP 6255A in operation, to operate it, and to perform emergency repair. Although shipped separately packed they must accompany the HP 6255A during operation and whenever it is transferred between accountable officers. The illustrations will assist you with hard-to-identify items. This manual is your authority to requisition replacement B II, based on TOE/MTOE authorization of the end item.

C-3. Explanation of Columns.

a. Illustration. This column is divided as follows:

(1) **Figure Number.** Indicates figure number of the illustration on which the item is shown.

(2) **Item Number.** The number used to identify item called out in the illustration.

b. National Stock Number. Indicates the National stock number assigned to the item and which will be used for requisitioning.

c. Part Number. Indicates the primary number used by the manufacturer, which controls the design and characteristics of the item by means of its engineering drawings, specifications, standards, and inspection requirements to identify an item or range of items.

d. Description. Indicates the Federal item name and, if required, a minimum description to identify the item.

e. Location. The physical location of each item listed is given in this column. The lists are designed to inventory all items in one area of the major item before moving on to an adjacent area.

f. Quantity Required (Qty Reqd). This column lists the quantity of each item required for a complete major item.

g. Quantity. This column is left blank for use during an inventory. Under the Rcv'd column, list the quantity you actually receive on your major item. The Date columns are for your use when you inventory the major item at a later date, such as for shipment to another site.

SECTION II. **INTEGRAL COMPONENTS OF END ITEM**

(1) Illustration		(2)	(3)	(4)	(5)	(6)	(7)	(8) Quantity			
(a) Figure No.	(b) Item No.	National Stock Number	Part No.	Description	Location	Usable On Code	Qty Reqd	Rcv'd	Date	Date	Date
C-1	1		HP 6255A	Power Supply (28480)			1				

SECTION III. BASIC ISSUE ITEMS

(1) Illustration		(2)	(3)	(4)	(5)	(6)	(7)	(8) Quantity			
(a) Figure No.	(b) Item No.	National Stock Number	Part No.	Description	Location	Usable On Code	Qty Reqd	Rev'd	Date	Date	Date
No Basic Issue Items											

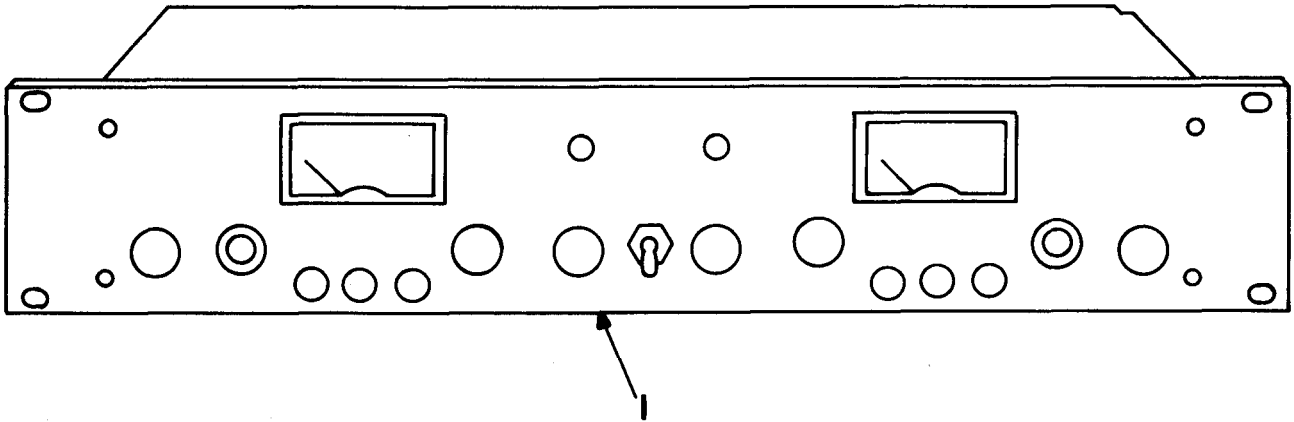

Figure C-1. Power Supply HP6255A

APPENDIX D

ADDITIONAL AUTHORIZATION LIST

Section I. INTRODUCTION

D-1. SOops. This appendix lists additional items you are authorized for the support of the HP 6255A.

authorized to you by CTA, MTOE, TDA, or JTA.

D-2. Gml. This list identified items that do not have to accompany the HP 6255A and that do not have to be turned in with it. These items are all

D-3. Explanation of Listing. National stock numbers, descriptions, and quantities are provided to help you identify and request the additional items you require to support this equipment.

SECTION II. ADDITIONAL AUTHORIZATION LIST

(1) National Stock Number	(2) Description Part Number & FSCM Usable on Code		(3) U/M	(4) Qty Auth
No Additional Authorized Items				

APPENDIX E

EXPENDABLE SUPPLIES AND MATERIALS LIST

Section I. INTRODUCTION

E-1 Scope. This appendix lists expendable supplies and materials you will need to operate and maintain the HP 6255A. These items are authorized*to you by CTA 50-970, Expendable Items (Except Medical, Class V, Repair Parts, and Heraldic Items).

E-2. Explanation of Columns.

a. Column 1 – Item Number. This number is assigned to the entry in the listing and is referenced in the narrative instructions to identify the material (e.g., "Use cleaning compound, item 5, App. D").

b. Columns 2 – Level. This column identifies the lowest level of maintenance that requires the listed item.

- C Operator/Crew
- O Organizational Maintenance
- F Direct Support Maintenance

H General Support Maintenance

c. Column 3 – National Stock Number. This is the National stock number assigned to the item; use it to request or requisition the item.

d. Column 4 – Description. Indicates the Federal item name and, if required, a description to identify the item. The last line for each item indicates the part number followed by the Federal Supply Code for Manufacturer (FSCM) in parentheses, if applicable.

e. Column 5 – Unit of Measure (U/M). Indicates the measure used in performing the actual maintenance function. This measure is expressed by a two-character alphabetical abbreviation (e.g., ea, in, pr). If the unit of measure differs from the unit of issue, requisition the lowest unit of issue that will satisfy your requirements.

(1) Item Number	(2) Level	(3) National Stock Number	(4) Description	(5) U/M
1	0	8305-267-3015	Cloth, cotton, cheesecloth	Roll
2	0	6810-00-292-9625	Trichlorotrifluoroethane OT620 (81349)	Oz

INDEX

Subject	Paragraph
A	
Accuracy, Rated Output and Meter	5-13
Adjustment and Calibration	
Ammeter Tracking	5-54
Constant Current Programming Current	5-61
Constant Voltage Programming Current	5-58
Constant Voltage Transient Response	5-64
Crowbar	Appendix A
Meter Zero	5-50
Reference Circuit	5-62
Voltmeter Tracking	5-52
Zero Current Programming	5-60
Zero Volt Programming	5-57
Ammeter	
Connections	4-40, 41
Tracking	5-54
Amplifiers	
Error	4-29, 30
Meter	4-39
Mixer	4-29

INDEX - Continued

Subject	Paragraph
Analysis	
Detailed Circuit	4-8
Trouble	5-41
Auto Parallel	3-41
Auto-Series	
Connections	3-37
Operations	1-5
Auto-Tracking Operation	1-5, 3-42
B	
Block Diagram Discussion	4-1
C	
Cable, Power	2-17
Calibration Adjustment	5-48
Capacitance, Output	3-48
Check	
Electrical	2-5
Mechanical	2-3
Circuit	
Analysis	4-8
Constant Current Input	4-20
Constant Voltage Input	4-16
Meter	4-34
Reference	4-31

INDEX - Continued

Subject	Paragraph
Reference Adjustment	5-62
Voltage Clamp	4-25
Connecting Load	3-11
Connections	
Auto-Parallel	3-41
Auto-Series	3-37
230V Operation	2-15
Front Panel Terminal	5-6
Meter	4-40, 41
Normal Parallel	3-40
Normal Series	3-36
Constant Current	3-9
Input Circuit	4-20
Programing Current	5-59
Remote Programming	3-24
Tests	5-34
Constant Voltage	3-7
Input Circuit	4-16
Programming Current	5-56
Remote Programming	3-17
Tests	5-12
Transient Response	5-64
Controls and Indicators	3-1

INDEX - Continued

Subject	Paragraph
Crowbar	
Description and Operation	1-9, 3-55
Trip Voltage	1-9, 3-55
Current Reverse Loading	3-53
D	
Description	1-1
Divider Voltage	4-27
Electrical Check	2-5
Error Amplifiers	4-29, 30
Equipment, Required Test	5-8
Feedback Loop	4-9
Front Panel	
Operating Controls and Indicators	3-1
Terminal Connections	5-6
G	
General Measurement Techniques	5-3
I	
Indicators, Controls	3-1
Information Ordering	RPSTL
Initial Inspection	2-1

INDEX - Continued

Subject	Paragraph
Input Circuit	
Constant Current	4-20
Constant Voltage	4-16
Input Power Requirements	2-13
Installation Data	2-7
Instrument Identification	1-10
Introduction	
Maintenance	5-1
Replaceable Parts	6-1
L	
Line Regulation	5-17, 36
Load Regulation	5-16, 35
Location	
Installation	2-9
Loading	
Pulse	3-46
Reverse Current	3-53
Reverse Voltage	3-51
Loop, Feedback	4-9
M	
Maintenance	5-1
Maintenance Allocation Chart	Appendix B
Measurement Techniques, General	5-3
Mechanical Check	2-3

INDEX - Continued

Subject	Paragraph
Meter	
Accuracy	5-13
Amplifier	4-39
Circuit	4-34
Zero	5-50
Mixer Amplifier	4-29
Mode (s)	
Normal Operating	3-5
Operating	3-3
Optional Operating	3-16
Mounting, Rack	2-11
	N
Normal Operating Mode	3-5
	O
Ordering	
Information	RPSTL
Replacement Parts	RPSTL
Options	1-8
Operating	
Controls and Indicators	3-1
Modes	3-3
Normal Mode	3-5
Optional Modes	3-16

INDEX - Continued

Subject	Paragraph
Operation	
Auto-Parallel	3-41
Auto-Tracking	3-42
Supply Beyond Rated Output	3-14
Parallel	3-39
Series	3-35
Ordering Information	RPSTL
Output	
Capacitance	3-48
Impedance	5-33
Overall Block Diagram Discussion	4-1
	P
Parallel Operation	3-39
Auto	3-41
Performance Test	5-10
Power	
Cable	2-17
Input Requirements	2-13
Programming Current	
Constant Current	5-59
Constant Voltage	5-56
Programming, Remote	
Constant Current	3-24
Constant	
Voltage	3-17

INDEX - Continued

Subject	Paragraph
Programming Speed	5-32
Principles of Operation	
Detailed Circuit Analysis	4-8
Overall Block Diagram Discussion	4-1
Pulse Loading	3-46
R	
Rack Mounting	2-11
Rated Output and Meter Accuracy	5-13
Recovery Time, Transient	5-31
Reference Circuit	4-31
Adjustments	5-62
References	Appendix A
Regulation	
Line	5-17, 36
Load	5-16, 35
Regulator Series	4-14
Remote Programming	
Constant Current	3-24
Constant Voltage	3-17
Remote Sensing	3-30
Repackaging for Shipment	2-20
Repair and Replacement	5-46
Required Test Equipment	5-8

INDEX - Continued

Subject	Paragraph
Resistance Programming	
Voltage	3-19
Current	3-26
Reverse Loading	
Current	3-53
Voltage	3-51
Ripple and Noise	5-18, 19, 37
Measurements	5-21, 38
S	
Sensing, Remote	3-30
Series	
Operation	3-35
Regulator	4-14
Simplified Schematic	4-5
Shipment, Repackaging for	2-20
Special Operating Considerations	3-45
Specifications	1-6
T	
Techniques, General Measurement	5-3
Test(s)	
Constant Current	5-34
Constant Voltage	5-12
Equipment Required	5-8
Performance	5-10

INDEX - Continued

Subject	Paragraph
Tool and Test Equipment Requirements	Appendix B
Tracking	
Ammeter	5-54
Auto	3-42
Voltmeter	5-52
Transient	
Recovery Time	5-31
Response	5-64
Trouble	
Analysis	5-41
Shooting	5-39
V	
Voltage	
Clamp Circuit	4-25
Constant	3-7
Input Circuit Constant	4-16
Programming Current, Constant	5-56
Remote Programming, Constant	3-17
Reverse Loading	3-51
Tests Constant	5-12
Voltmeter Tracking	5-52

RECOMMENDED CHANGES TO EQUIPMENT TECHNICAL PUBLICATIONS



THEN... JOT DOWN THE DOPE ABOUT IT ON THIS FORM. CAREFULLY TEAR IT OUT, FOLD IT AND DROP IT IN THE MAIL!

SOMETHING WRONG WITH THIS PUBLICATION?

FROM: (PRINT YOUR UNIT'S COMPLETE ADDRESS)
 Commander
 Stateside Army Depot
 ATTN: AMSTA-US
 Stateside, N.J. 07703

DATE SENT
 4 April 1978

PUBLICATION NUMBER TM 11-5840-340-14&P	PUBLICATION DATE 23 Jan 74	PUBLICATION TITLE Radar Set AN/PRC-76
---	-------------------------------	--

BE EXACT... PIN-POINT WHERE IT IS				IN THIS SPACE TELL WHAT IS WRONG AND WHAT SHOULD BE DONE ABOUT IT:
PAGE NO	PARA-GRAPH	FIGURE NO	TABLE NO	
2-25	2-28			<p>Recommend that the installation antenna alignment procedure be changed throughout to specify a 2° IFF antenna lag rather than 1°.</p> <p>REASON: Experience has shown that with only a 1° lag, the antenna servo system is too sensitive to wind gusting in excess of 25 knots, and has a tendency to rapidly accelerate and decelerate as it hunts, causing strain to the drive train. Hunting is minimized by adjusting the lag to 2° without degradation of operation.</p>
3-10	3-3		3-1	<p>Item 5, Function column. Change "2 db" to "3db."</p> <p>REASON: The adjustment procedure the TRANS POWER FAULT indicator calls for a 3 db (500 watts) adjustment to light the TRANS POWER FAULT indicator.</p>
5-6	5-8			<p>Add new step f.1 to read, "Replace cover plate removed in step e.1, above."</p> <p>REASON: To replace the cover plate.</p>
E-5				<p>For item 2, change the NSN to read: 5835-00-134-9186.</p> <p>REASON: Accuracy.</p>
E-8		E-3		<p>Identify the cover on the junction box (item no. 5).</p> <p>REASON: It is a separate item and is not called out on figure 19.</p>
E-9				<p>Add the cover of the junction box as an item in the listing for figure 19.</p> <p>REASON: Same as above.</p>

TEAR ALONG PERFORATED LINE

PRINTED NAME, GR/DE OR TITLE, AND TELEPHONE NUMBER
 SSG I. M. DeSpirito 999-1776

SIGN HERE

DA FORM 2028-2
 1 JUL 79

PREVIOUS EDITIONS ARE OBSOLETE.

P.S.--IF YOUR OUTFIT WANTS TO KNOW ABOUT YOUR RECOMMENDATION MAKE A CARBON COPY OF THIS AND GIVE IT TO YOUR HEADQUARTERS.

RECOMMENDED CHANGES TO EQUIPMENT TECHNICAL PUBLICATIONS

SOMETHING WRONG WITH THIS PUBLICATION?



THEN...JOT DOWN THE DOPE ABOUT IT ON THIS FORM. CAREFULLY TEAR IT OUT, FOLD IT AND DROP IT IN THE MAIL.

FROM: (PRINT YOUR UNIT'S COMPLETE ADDRESS)

DATE SENT

PUBLICATION NUMBER
TM 11-6130-416-14

PUBLICATION DATE
31 January 1983

PUBLICATION TITLE
Power Supply, Dual DC
H-P Model 6255A

BE EXACT PIN-POINT WHERE IT IS

PAGE NO.	PARA-GRAPH	FIGURE NO.	TABLE NO.

IN THIS SPACE TELL WHAT IS WRONG AND WHAT SHOULD BE DONE ABOUT IT:

TEAR ALONG PERFORATED LINE

PRINTED NAME GRADE OR TITLE AND TELEPHONE NUMBER

SIGN HERE

FILL IN YOUR
UNIT'S ADDRESS

FOLD BACK

DEPARTMENT OF THE ARMY

OFFICIAL BUSINESS
PENALTY FOR PRIVATE USE \$300

POSTAGE AND FEES PAID
DEPARTMENT OF THE ARMY
DOD 314



TEAR ALONG PERFORATED LINE

Commander
US Army Communications-Electronics Command
and Fort Monmouth
ATTN: DRSEL-ME-MP
Fort Monmouth, New Jersey 07703

FILL IN YOUR
UNIT'S ADDRESS

FOLD BACK

DEPARTMENT OF THE ARMY

OFFICIAL BUSINESS
PENALTY FOR PRIVATE USE \$300

POSTAGE AND FEES PAID
DEPARTMENT OF THE ARMY
DOD 314



TEAR ALONG PERFORATED LINE

Commander
US Army Communications-Electronics Command
and Fort Monmouth
ATTN: DRSEL-ME-MP
Fort Monmouth, New Jersey 07703

RECOMMENDED CHANGES TO EQUIPMENT TECHNICAL PUBLICATIONS



THEN...JOT DOWN THE DOPE ABOUT IT ON THIS FORM. CAREFULLY TEAR IT OUT, FOLD IT AND DROP IT IN THE MAIL.

SOMETHING WRONG WITH THIS PUBLICATION?

FROM: (PRINT YOUR UNIT'S COMPLETE ADDRESS)

DATE SENT

PUBLICATION NUMBER
TM 11-6130-416-14

PUBLICATION DATE
31 January 1983

PUBLICATION TITLE
Power Supply, Dual DC
H-P Model 6255A

BE EXACT PIN-POINT WHERE IT IS

PAGE NO.	PARA-GRAPH	FIGURE NO.	TABLE NO.
----------	------------	------------	-----------

IN THIS SPACE TELL WHAT IS WRONG AND WHAT SHOULD BE DONE ABOUT IT:

TEAR ALONG PERFORATED LINE

PRINTED NAME GRADE OR TITLE AND TELEPHONE NUMBER

SIGN HERE

FILL IN YOUR
UNIT'S ADDRESS

FOLD BACK

DEPARTMENT OF THE ARMY

OFFICIAL BUSINESS
PENALTY FOR PRIVATE USE \$300

POSTAGE AND FEES PAID
DEPARTMENT OF THE ARMY
DOD 314



TEAR ALONG PERFORATED LINE

Commander
US Army Communications-Electronics Command
and Fort Monmouth
ATTN: DRSEL-ME-MP
Fort Monmouth, New Jersey 07703

By Order of the Secretary of the Army, the Navy, and the Air Force

E. C. MEYER
General United States Army
Chief of Staff

Official:

ROBERT M. JOYCE
Major General United States Army
The Adjutant General

G. B. SHICK
Rear Admiral, United States Navy
Commander, Naval Electronic
Systems Command

CHARLES A. GABRIEL, *General USAF*
Chief of Staff

Official:

JAMES P. MULLINS
General USAF, Commander, Air Force
Logistics Command

DISTRIBUTION :

To be distributed in accordance with Special List.

☆ U.S. GOVERNMENT PRINTING OFFICE : 1989 O - 242-451 (1247)

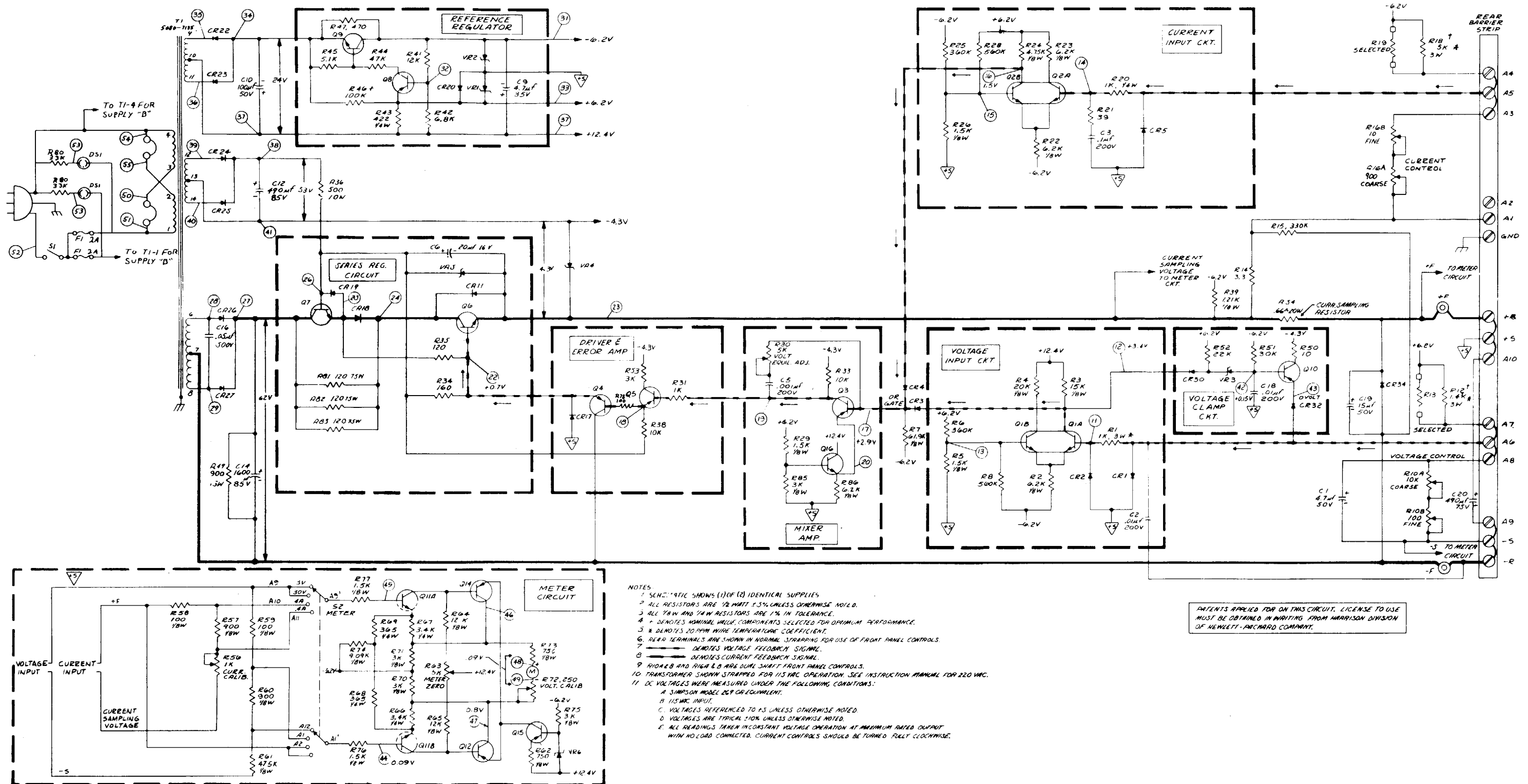

PATENTS APPLIED FOR ON THIS CIRCUIT. LICENSE TO USE MUST BE OBTAINED IN WRITING FROM HARRISON DIVISION OF HENLETT-FRICHARD COMPANY.

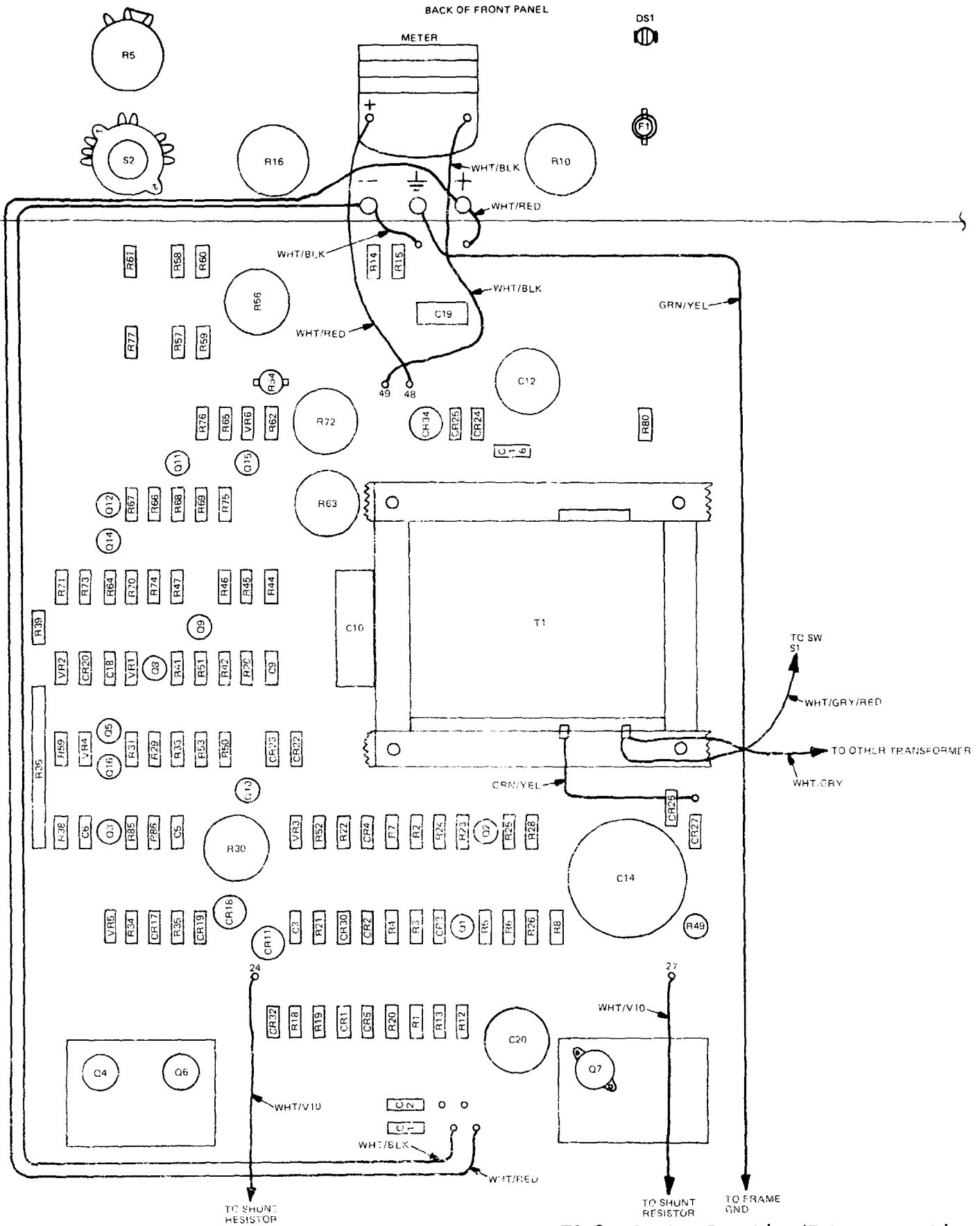

FO-2. Parts Location/Interconnection Diagram (Sheet 1 of 3)

BACK OF FRONT PANEL

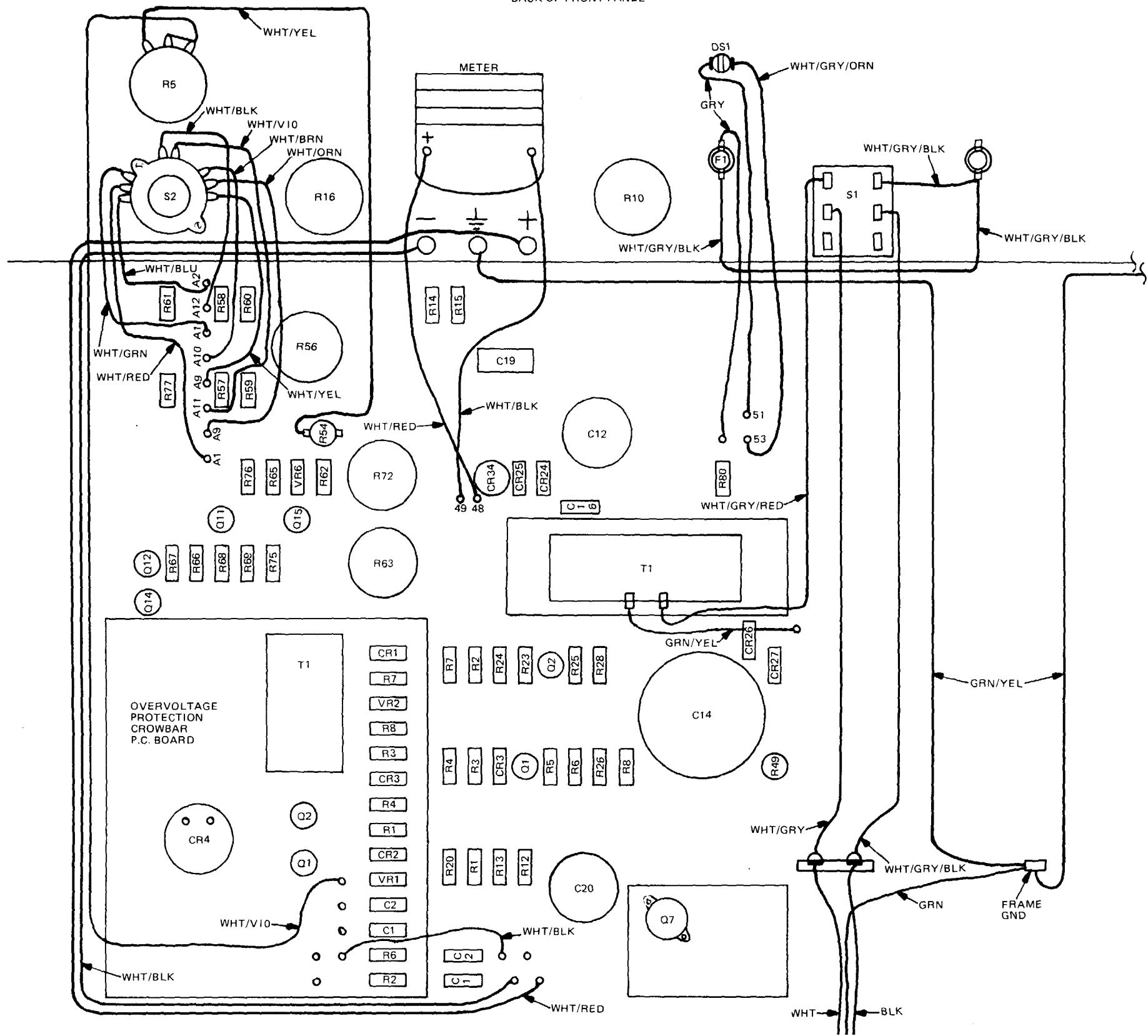

FO-2. Parts Location/Interconnection Diagram (Sheet 2 of 3)

BACK OF FRONT PANEL

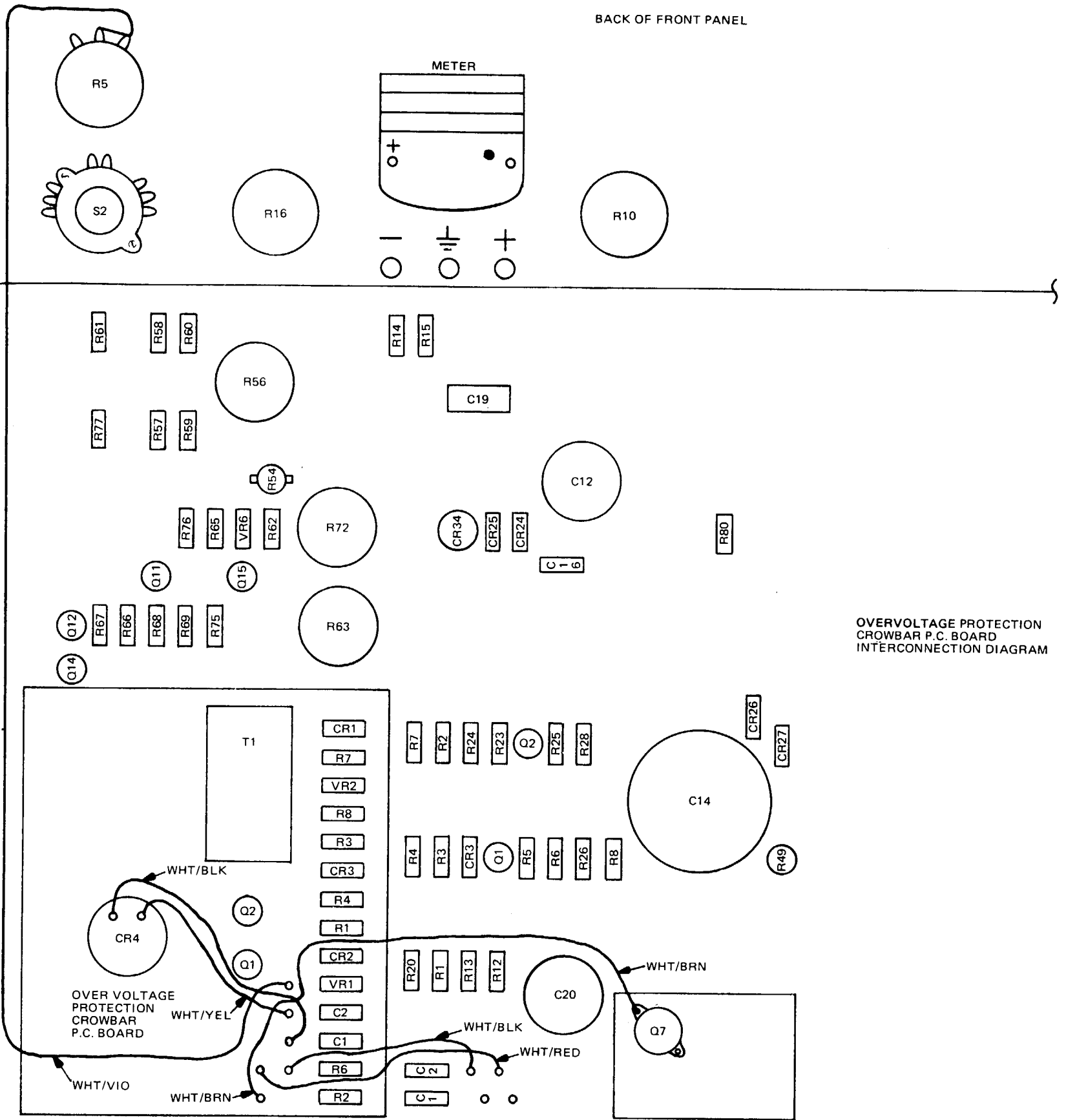

OVERVOLTAGE PROTECTION
CROWBAR P.C. BOARD
INTERCONNECTION DIAGRAM

FO-2. Parts Location/Interconnection
Diagram (Sheet 3 of 3)

